

UNIVERSITY OF KENTUCKY

COLLEGE OF AGRICULTURE

Extension Division

THOMAS P. COOPER, Dean and Director

CIRCULAR NO. 329

BLUE MOLD OF TOBACCO AND
ITS CONTROL

Lexington, Ky.

January, 1939

Published in connection with the agricultural extension work carried on by co-operation of the College of Agriculture, University of Kentucky, with the U. S. Department of Agriculture and distributed in furtherance of the work provided for in the Act of Congress of May 8, 1914.

This report was prepared cooperatively by a committee composed of representatives from Duke University, the Agricultural Experiment Stations and Extension Services of Virginia, North Carolina, and South Carolina, and the North Carolina Department of Agriculture. The information contained in it seems to be as applicable to Kentucky as to the states for which it was prepared. It is reprinted with permission of the committee.

B

TI
blue r

Bl
lower
down
tobac

B
on se
other
dews
grasse

B
and i
tobac
withi
For s
when
South
invad
Wisc
peara
the U
with

F
mold
destr
have
of gr
epide
in the

Blue Mold (Downy Mildew) of Tobacco and Its Control

The purpose of this report is to give the grower a better understanding of the blue mold disease of tobacco and to describe effective methods to combat it.

NAME OF THE DISEASE

Blue mold derives its name from the color of the downy growth found on the lower side of diseased leaves. Pathologists call similar diseases on other plants downy mildews. The names downy mildew and blue mold, when applied to tobacco, refer to one and the same disease.

PLANTS ATTACKED

Blue mold of tobacco may be found on all cultivated varieties of tobacco, and on seedlings of tomato, pepper, and egg-plant, but it is not known to involve any other kinds of plants. The disease should not be confused with the downy mildews of any other crops or with the white powdery mildews common on trees, grasses, clovers, roses, etc., all of which are caused by other species of fungi.

HISTORY OF THE DISEASE

Blue mold of tobacco has probably been present in Australia since about 1850, and it may be native to Australia since the disease occurs there on certain native tobaccos. Apparently the first outbreak of this disease on cultivated tobacco within the United States occurred in 1921, when it appeared in Florida and Georgia. For some unknown reason it did not again attract attention until 10 years later when it reappeared in Florida and Georgia, and spread rapidly into Louisiana, South Carolina, North Carolina, Virginia, and Maryland. Since then it has invaded all of the tobacco-producing states east of the Mississippi River, except Wisconsin. It has also been reported from Canada, where it made its first appearance in 1938. The disease is now firmly established in the eastern area of the United States, and it is reasonable to expect that growers will be confronted with the problem of its control every year.

ECONOMIC IMPORTANCE

From the standpoint of individual growers, the economic importance of blue mold cannot be over-estimated because plants in entire seed beds have been destroyed within a few days. In certain communities, losses up to 95 percent have been observed. In 1932 and 1937, the disease was so severe that hundreds of growers were forced to secure plants from adjoining communities. In these epidemic years the disease was responsible for a reduction of from 20 to 50 percent in the tobacco acreage in some communities.

SYMPTOMS OF THE DISEASE

The symptoms of the disease on young and old plants frequently differ.

In Seed Beds. The first appearance of the disease generally coincides with the blooming of the flowering dog-wood. As a rule the disease is first found in beds located on the sites where there were beds the previous year. In such beds large numbers of small plants may be quickly killed. Close inspection of the first affected plants, regardless of whether they are very small or are large enough for

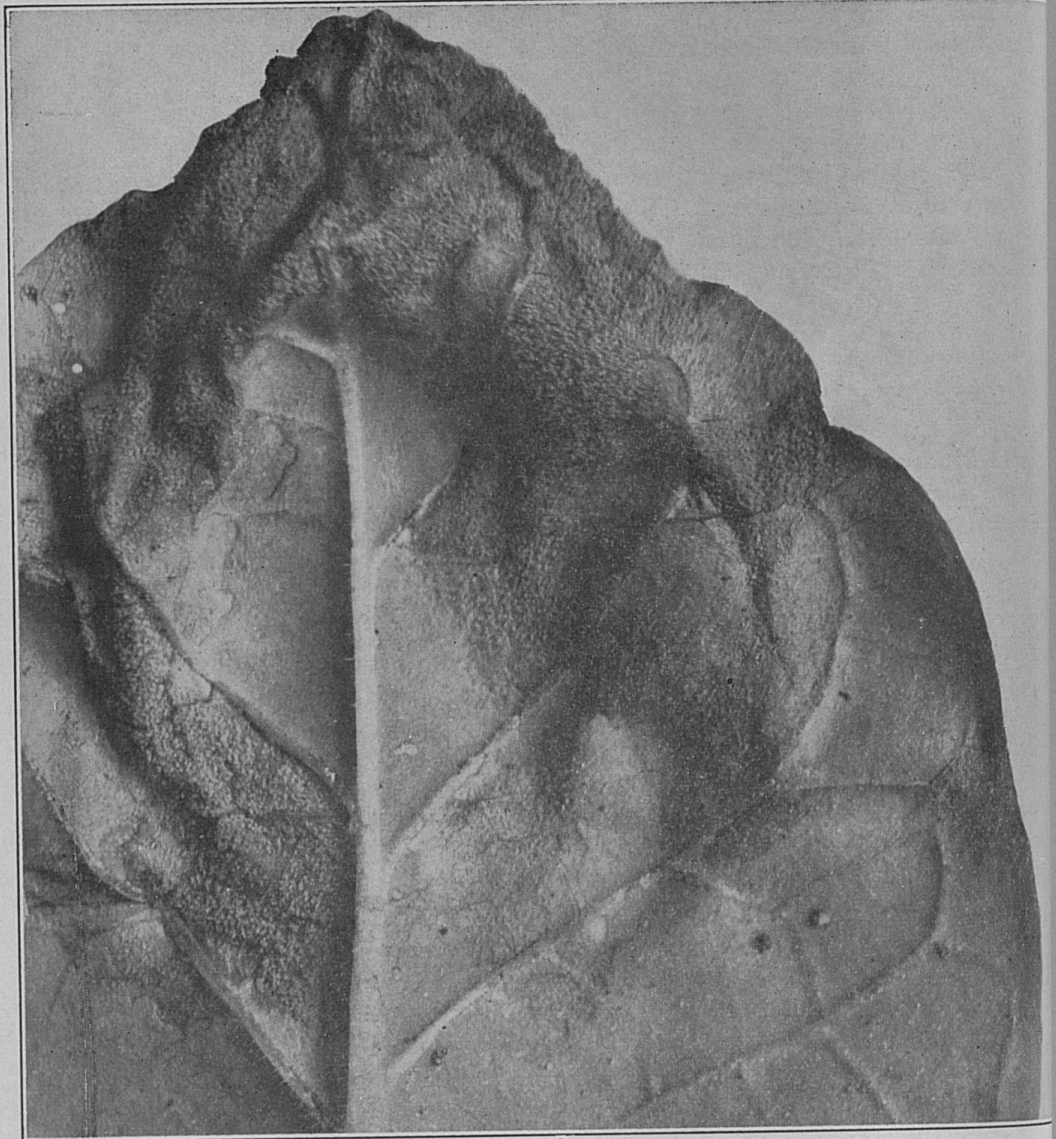

Fig. 1.—Blue mold or downy mildew of tobacco as seen on the lower side of the leaf. Slightly enlarged.

transplanting, shows a downward cupping of the tips of the leaves. Almost overnight a dense bluish or gray downy mold develops on the lower surfaces (Fig. 1) of the leaves. The upper surfaces of the leaves at this time usually show a dead green or slightly yellow color if the weather has been moist and cool. Later, the leaves appear scalded and have a characteristic odor of decay. If the weather

has be
large y
coating
attack.

Fig.
weather

has been dry and warm and the plants are hardened, dark brown specks within large yellow spots may appear. During such weather, there is little if any downy coating of mold on the leaves (Fig. 2), and the seedlings may recover from an attack. If the weather again becomes cool and moist they may again be attacked.

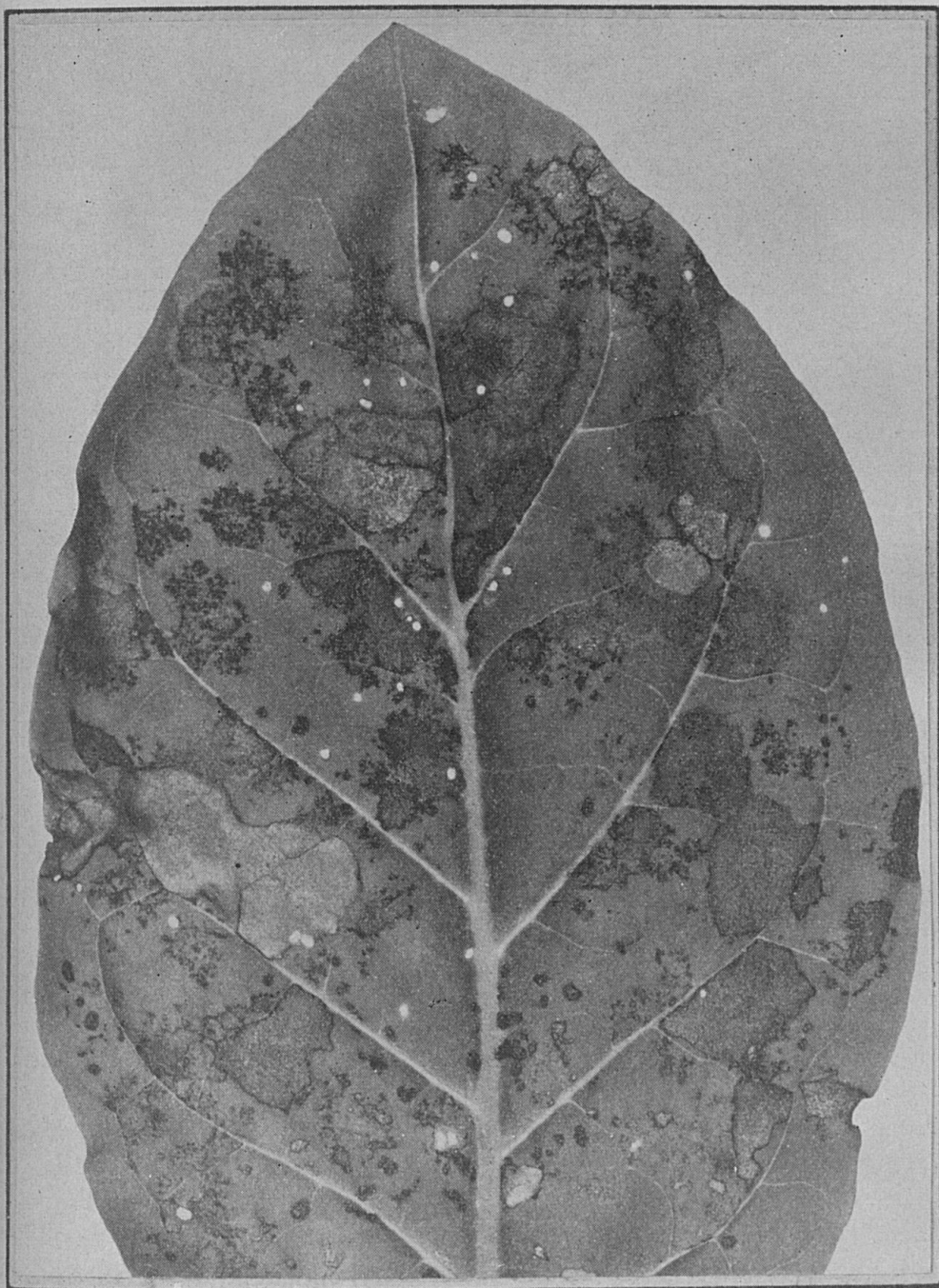

Fig. 2.—The appearance of the blue mold disease on older leaf of seedling during dry warm weather. The downy coating is sparse or entirely absent under such conditions. Natural size.

In the Field. Plants may be affected in the field, if protracted cool wet weather follows transplanting. During such weather groups of small yellow spots appear forming circular blotches similar to those on seed bed leaves (Fig. 3). Sometimes larger yellow spots develop causing the leaves to pucker. Ultimately large circular decayed areas are formed and the leaves become torn and ragged. The

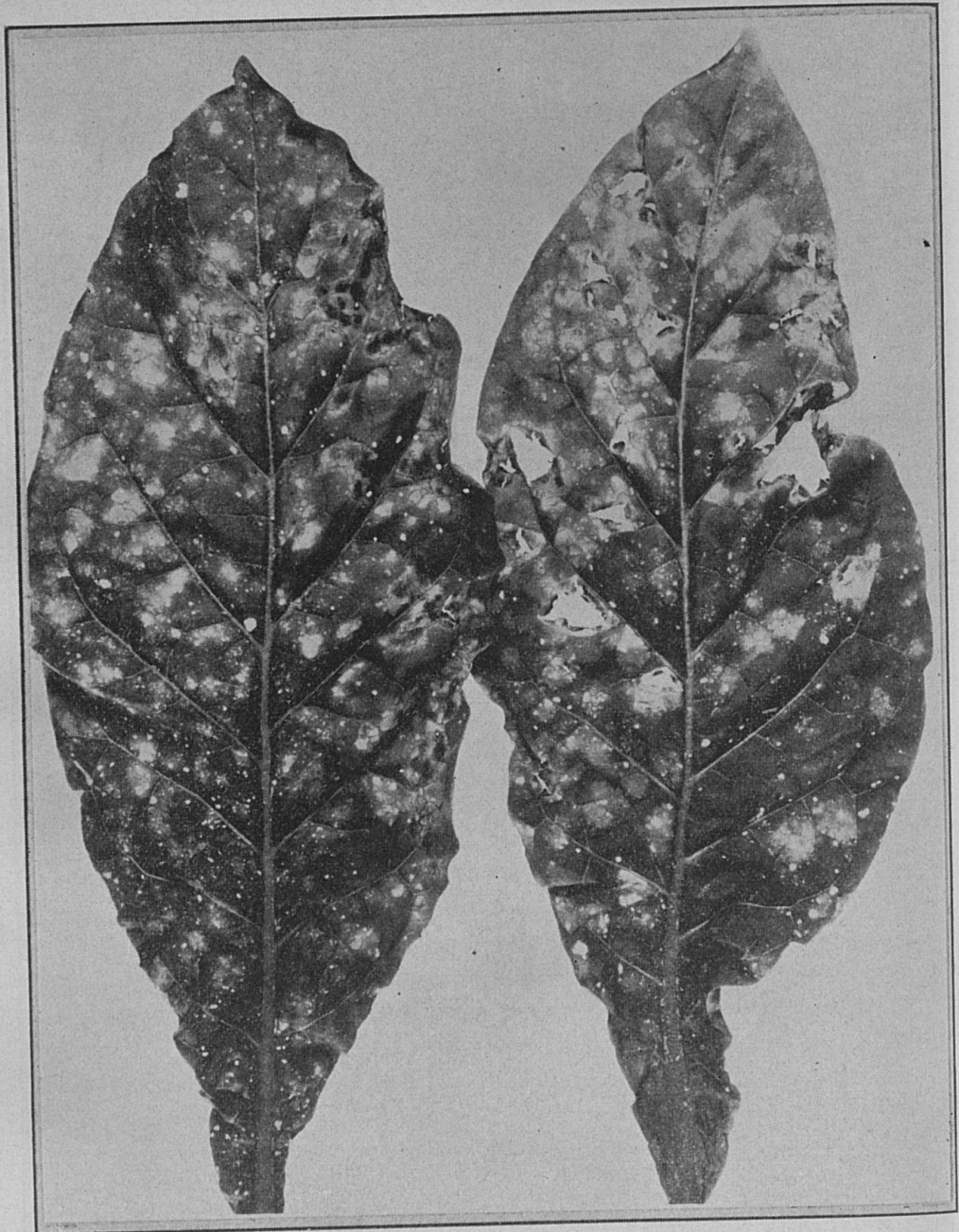

Fig. 3.—Advanced symptoms of downy mildew on the lower leaves of field grown plants. Both large and small dead spots are commonly formed.

infection of plants in the field has been reported on several occasions but it has never been so abundant as to cause alarm except in 1938. As hot weather approaches the disease disappears from the field.

Since downy mildew (blue mold) infection of field-grown tobacco plants may arise from air-borne sporangia from nearby seed beds, it appears advisable to plow under or burn over tobacco seed beds as soon as possible after adequate field stands are obtained.

CAUSES OF THE DISEASE AND LIFE CYCLE OF THE CASUAL FUNGUS

The cause of this tobacco disease is a mold or fungus that reproduces itself by two kinds of seed-like bodies or spores. One of these kinds occurs in the downy coating on the lower surface of diseased leaves and is the chief means by which the mold is spread in the spring. These seed-like bodies are called "sporangia." The other kind forms in the decaying leaves, remains dormant throughout the summer, fall, and winter, and starts the disease the following spring. These seed-like bodies are known as "oospores."

Under the microscope sporangia appear as minute egg-shaped bodies about one-thousandth of an inch in length (Fig. 4, C). They are formed at the ends of the branches of small tree-like structures on the lower side of diseased leaves (Fig. 4, A). The sporangia usually begin their development in early morning with the coming of dawn and are mature by sunrise. On dark cloudy days sporangia may be produced continuously so long as the leaf is able to support the growth of the mold.

Sporangia must germinate on healthy leaves in order to cause them to become diseased. Upon germination slender tubes (Fig. 4, B), are formed if there is a film or drop of water on the leaf. Following germination, the slender tubes enter the leaf (Fig. 4, D), where they develop by branching into a web that may extend throughout the entire leaf and into the stem. From this web within the leaf, tree-like structures emerge and bear sporangia at the ends of the branches.

The sporangia are produced in countless numbers. Since they are small and dust-like they may be readily distributed by air currents, thus making it possible for the fungus to be spread widely. Observations show that these small bodies readily stick to the hands and clothing, so that, while weeding, one may spread the sporangia from infected areas within the bed to non-infected ones, even to near-by healthy beds.

After sporangia have lodged on the leaves of healthy plants a period of 3 to 7 days only is required before such plants are visibly diseased as shown by the presence of sporangia. These sporangia may then be spread by air currents to other healthy tobacco seedlings, and the cycles of infection and production of sporangia may be repeated several times in a season.

The oospores are formed within a few days after the tissues of the leaves have been killed. They are ball-shaped, and slightly less than one-five-hundredth of an inch in diameter (Fig. 4, F, G, H, I). A thick, resistant wall aids them in surviving from one spring until the next, even though the leaves within which they formed are completely decayed. Oospores, remaining alive in the soil of the bed, may cause the seedlings to become infected in case the same site is used for a tobacco seed bed the next year. This explains why downy mildew may appear earliest in beds sown on old bed sites and why these beds are sources from which the fungus spreads to cause a general outbreak of the disease about 3 weeks later.

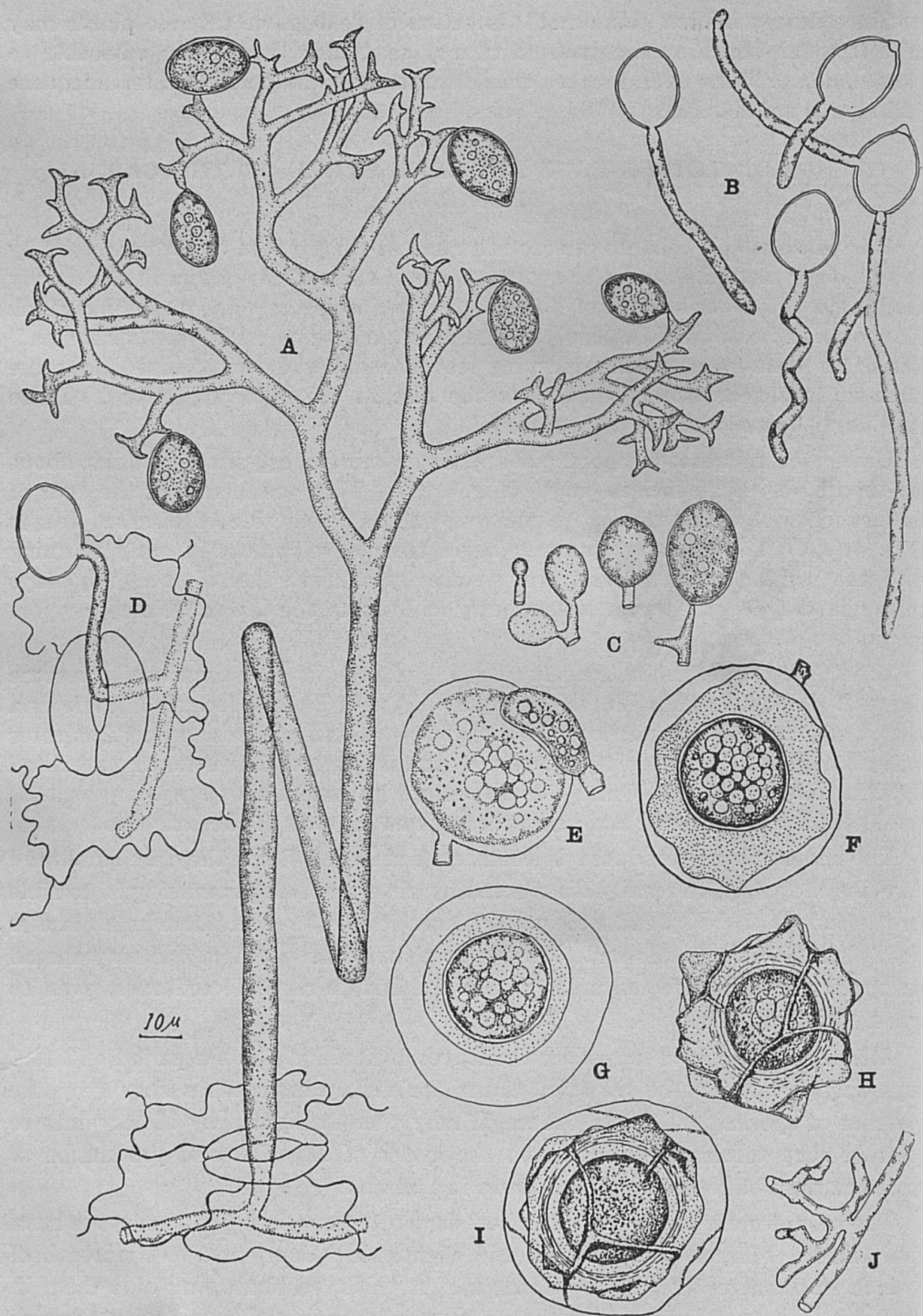

Fig. 4.—The appearance of the downy mildew parasite under the microscope. A. A tree-like fruiting branch of the downy mildew fungus. The stalk is folded and most of the egg-shaped sporangia have fallen off. The downy coating is caused by the large number of these structures. B. Germinating sporangia, showing thread-like tubes. C. Stages in the formation of sporangia at the tips of the branches. D. The tube from a germinating sporangium showing its entrance into a breathing pore. E, F, G, H, and I. Stages in the formation of oospores. J. Branched thread of the downy fungus by means of which it obtains food from the cells of the tobacco leaf.

FACTORS AFFECTING DISEASE DEVELOPMENT

Growers are well aware of the variable nature of the blue mold disease since it may appear in seed beds either early or late, and be severe or mild depending upon such factors as seed bed site, time of infection, size and vigor of seedlings, and weather conditions.

Seed Bed Sites. Observations show that ordinarily the first outbreaks of blue mold occur in beds located on sites of old beds that were diseased the previous year. However, the disease may not always appear first in all beds sowed on old sites in a given community. These first outbreaks arise from oospores that have survived in the soil of old beds. For this reason it is best that old bed sites be avoided and that beds be located in a different place each year. As an additional precaution to be taken in locating beds it is advisable that good air drainage with proper exposure to the sun be provided, since swampy, shaded places, closely surrounded by woods, are favorable for the growth of the mold.

Time of Infection. Tobacco seedlings of any age may become infected. If the seedlings are growing on sites where diseased beds were located the previous year and if oospores survived, an outbreak may occur by the time the seedlings have reached the 4-leaf stage. Observations show that blue mold may occur shortly after the first spell of warm weather. At this time there may be so few affected plants that they escape notice, unless a most careful inspection is made. About a week later, however, the disease is easily noticed because small patches of plants will have become affected. The sporangia formed on these few diseased plants are carried by the wind throughout that bed and to other beds, frequently for several miles. A general outbreak of blue mold in all seed beds then follows within 3 to 4 weeks after the disease makes its first appearance in the community.

Size and Vigor of Seedlings. Plants are less likely to survive if attacked while small than they are if attacked when they have reached the stage for transplanting. Larger plants may recover even though all but the bud leaves are destroyed. A greater number of seedlings are killed if they are growing densely crowded than if the stands are thinner. *Affected seedlings should not be transplanted in the field until after new roots have formed.*

Weather Conditions. Blue mold may be very destructive in some seasons and cause little damage in others. It may spread throughout the bed very rapidly or it may progress slowly. The peculiar behavior of the disease can be explained, in part, by weather conditions. Continued cloudy, rainy weather, especially if accompanied by winds, is favorable for the development and spread of the disease, and bright warm days are known to retard it. If the temperature at night ranges around 56°F. conditions are very favorable for the abundant production of sporangia; but, if the temperature is 68°F. or above, few sporangia will be formed. Low temperatures at night retard the growth of blue mold, but frosts do not kill the sporangia. High temperature during the day also hinders the growth of the mold.

Moisture is equally important as temperature in governing the course of this disease. Rain or dew on the leaves is necessary for the germination of the sporangia and for the entrance of the mold into the leaves. Favorable conditions for infection are provided if leaves remain wet from 2 to 3 hours after sunrise. Obviously the longer the leaves remain wet the more favorable the conditions for infection and the more severe the disease. It is for these reasons that proper ventilation and air drainage be provided, and that swampy, poorly drained locations be avoided.

Sunlight affects the development of the disease in several ways. Exposure of sporangia to sunlight for an hour or two destroys them. Seedlings in shaded beds remain wet longer and thus are more subject to infection than those in beds exposed to sunlight. Removal of covers from seed beds makes the plants grow more slowly and as a consequence they are hardened and less likely to be killed by blue mold.

Fertilization. The use of commercial fertilizers and fertilizer materials to control blue mold has been uniformly unsuccessful in spite of claims to the contrary. The judicious and timely use of nitrate of soda, however, has proved useful in promoting the recovery of diseased seedlings.

PLANT BED PREPARATION

As a result of extensive investigations on the control of blue mold of tobacco, two methods of treatment have been developed. These are (1) fumigation, and (2) spraying. Regardless of the treatment used, however, a standard type of seed bed should be constructed. The use of narrow seed beds is strongly recommended because experience has shown that narrow seed beds have the following advantages:

- (1) More plants are produced per square yard in narrow beds.
- (2) The use of narrow beds avoids the necessity of trampling on plants while weeding the bed or pulling plants.
- (3) Narrow seed beds are easier to weed and to water.
- (4) Treatments of any kind are more easily applied in narrow beds.
- (5) The control of tobacco mosaic or wallon is easier to accomplish in narrow beds.
- (6) Cloth to make covers of the proper width can be purchased, avoiding the necessity of sewing covers together.
- (7) Tight fitting of covers can be accomplished more easily on narrow beds, which results in less damage from tobacco flea beetle.

The seed bed may be of any desired length but should be only 2 yards wide. A pathway 18 inches or 2 feet wide should be left between the beds.

Obviously the seed bed should be located near the owner's residence and near a source of water. A warm location is desirable but if fumigation is to be used, the seed bed site is of little concern since blue mold can be held in check. If spray treatments are to be used, the seed bed should have every possible advantage of sunlight, warmth, and air drainage.

Prior to the appearance of the blue mold disease as an economic problem in the United States, 100 square yards of seed bed was considered sufficient to produce seedlings to plant 3 to 4 acres. Within the past few years, however, growers have learned to plant 2 to 3 times this amount of seed bed area in the hope of obtaining a sufficient number of plants. If fumigation is practiced, no additional seed bed area need be provided, but, if the spray treatment is applied, it is advisable to plant additional seed bed area since there may be loss of plants even though they are sprayed.

The beds should be framed tightly with boards 8 to 10 inches wide. Soil should be drawn up against the boards along the outside of the bed. All cracks and places where vapors might escape should be carefully covered.

Seed bed covers of the usual kind should be used up to the time the blue mold fungus appears. Thereafter, if the beds are fumigated, a heavier cover will have

to be substituted as described later. If the beds are to be sprayed the usual cover should be used throughout the season.

It is very important that the seed beds be inspected daily for the first signs of the disease in order to avoid unnecessary loss of plants.

CONTROL TREATMENTS

Many difficulties have been met while developing methods for the control of tobacco blue mold because the treatments used for diseases of other crops were not entirely satisfactory when applied to tobacco, and therefore, new methods of procedure had to be devised. The grower should bear in mind that the methods outlined below are the best available at the present time and that if improved methods appear they will be made available. Three methods of treatment are given and it is hoped that each grower will select the one which seems to best suit his needs.

BENZOL (BENZENE) FUMIGATION

Preparation for Fumigation and Materials Used. Fumigation was tried because vapor or gases could be expected to reach all above ground portions of tobacco seedlings. Benzol was selected because its vapors are very poisonous to the mold but are tolerated in much greater strengths by tobacco seedlings.

If narrow seed beds are used fumigation is materially simplified. Pans (evaporators), benzol, and cotton sheeting must be obtained to complete the equipment needed. The evaporators, sheeting, and seed bed framing should be serviceable for several years.

Benzol Evaporators. Benzol evaporators should be ample to distribute a strength of benzol vapor throughout the seed bed sufficient to destroy the mold fungus yet be harmless to the tobacco seedlings.

Pan Type Evaporators (Fig. 5). Pan evaporators consist of open tin pans each of which has a surface of not less than 70 square inches nor more than 100 square inches. If round pans are used, the diameter should be 10 to 12 inches. The combined area of the standard pan type evaporators should be at least $1/72$ of the seed bed area. The depth of each pan should be sufficient to hold one pint of liquid without danger of spilling, and the sides should be low enough to prevent trapping the vapor above the liquid. The pans may be supported on frames, blocks, or wire legs of sufficient height to hold the pan above the plants (Fig. 5). Provision must be made to keep rain out of the pans. Two methods are suggested, one being to erect a canopy over the pan, as illustrated (Fig. 5), the other to paint a water proof spot about 18 inches in diameter on the part of the cover directly over the pan. The cover should be held off the pan by a suitably bent limb or wire arch, and should be at least two inches above the edge of the pan. One pan is sufficient for each four square yards of seed bed. Pans should be properly spaced, as shown in Fig. 5.

Trough Type Evaporators. Metal troughs with two or three inch sides may be used if they are placed either across the bed as illustrated (Fig. 6), or lengthwise of the bed, the arrangement depending on the slope of the bed. Each six foot length of trough is sufficient for eight square yards of seed bed area, and they should be properly spaced as illustrated in Fig. 6. Covers for the troughs should be provided as with the pans.

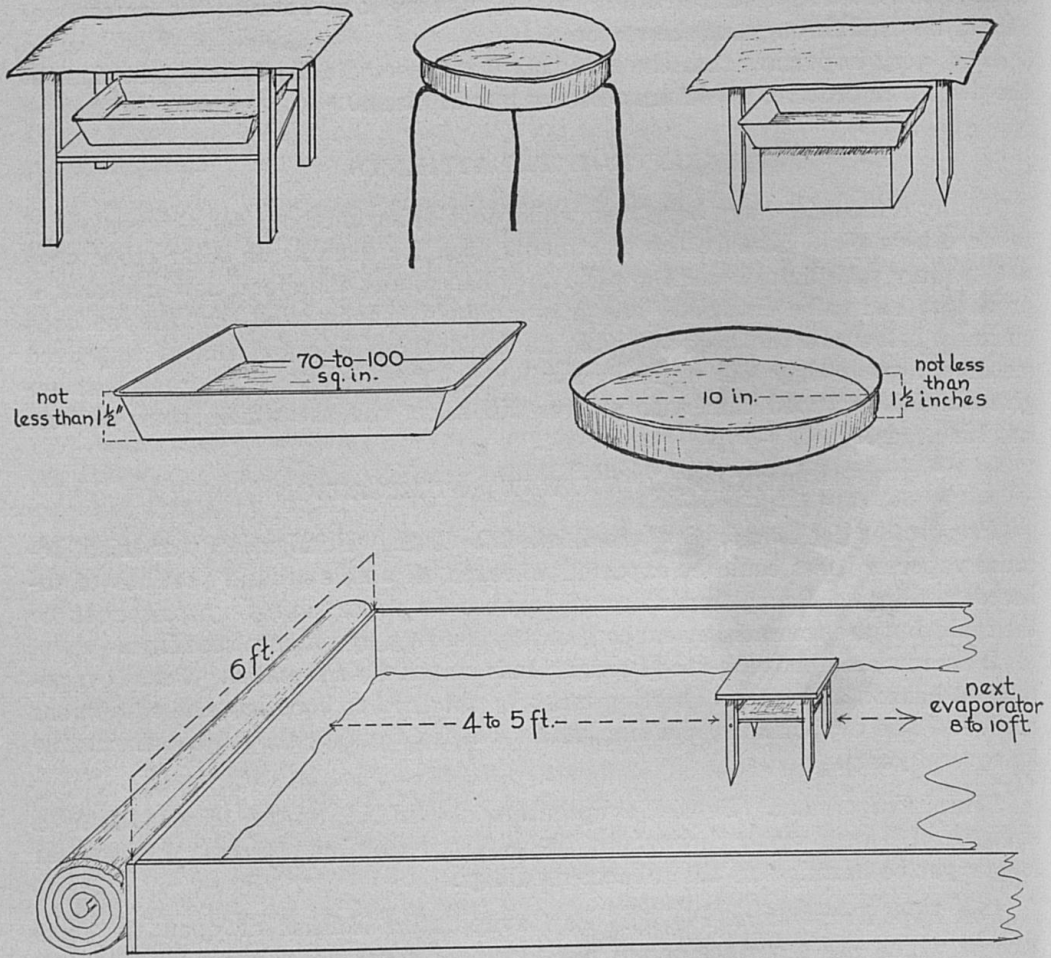

Fig. 5.—Plan showing evaporators, stands, covers, and spacing of evaporators within the seed-bed used in fumigating with benzol.

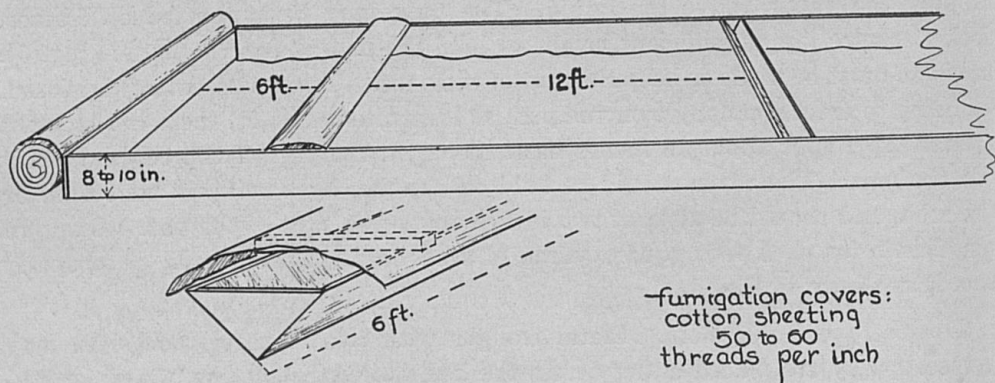

Fig. 6.—Plan of trough evaporators with covers, and the arrangement of these troughs used in fumigating with benzol.

Other Types of Evaporators. Semi-Automatic lamp wick evaporators, fed through a small pipe line, have been perfected adequately to distribute the vapors throughout the beds. They have certain advantages over pans or troughs and have proved very satisfactory. It is expected that some of these evaporators will soon be on the market and that adequate instructions for their installation will be furnished with them.

Seed Bed Covers. The usual type of seed bed cover should be used until time to start fumigation. Since these covers are too porous to retain the vapors of benzol, a heavier cover must then be substituted. These covers should have about 50 to 60 threads each way per inch and a pound of this cloth should cover about four square yards. The cloth for a bed two yards wide should be about 80 inches wide to provide for shrinkage. Cloth of these specifications is available from dry-goods and mail order stores at a cost of about seven or eight cents per square yard.

*The Benzol.** Commercial benzol costing approximately 20 to 25 cents per gallon is satisfactory. Benzol must be handled with caution because it is inflammable. Do not spill it on the plants as the liquid kills them. It is best to avoid breathing the vapors of benzol since persons can be poisoned with benzol, and also to avoid putting ones hands in it.

Amount of Benzol to Use. In pan type evaporators, the amount of benzol needed, depends upon the severity of the disease. If the disease has not yet started, one pint of benzol per night, equally distributed among four pans, is sufficient. If, however, the mold is spreading in the seed bed, one-half pint of benzol per pan per night should be used until the disease is checked. This may require using the larger amount of benzol for two or three successive nights. Thereafter, use the smaller amount of benzol.

In trough type evaporators, one pint of benzol per night should be divided equally between two six foot troughs, but if the disease is not checked with this amount of benzol, one pint of benzol per night may be required for each trough to bring the mold under control. Two or three nights' treatment with the larger amount of benzol is usually sufficient to stop the disease. The smaller amount should then be used in subsequent treatments.

When to Start Fumigation. If the disease is in the vicinity it is best to start fumigation immediately. However, if careful *daily inspections* of seedlings are made in late afternoon, to insure finding the first signs of the disease, fumigation need not begin until the disease is actually present. Care should be exercised in avoiding even one night's delay since plants cannot be revived by the treatment and many may be killed by the fungus if there is delay in beginning the fumigation. *Don't let the sun go down on unprotected seedlings.*

How to apply the Benzol. At about sundown fill each evaporator with the required amount of benzol, taking care to avoid spilling and making sure that the evaporators are level, properly protected, and securely anchored to prevent overturning. Cover the bed with the heavy cloth that must be used instead of the ordinary cloth, and fasten it in place. Do not fasten it too tightly since it will shrink if new. *Thoroughly wet the cover* after it is in place to make it more efficient in keeping the vapors within the bed. If the cover is new it may be advisable to lightly brush the water into the cloth to insure thorough wetting. Finally examine the entire seed bed to make sure that there are no holes through which the vapor might escape.

*Commercial benzol is marketed by several companies whose addresses may be obtained from County Agents, or other specialists.

Usually the covers should be removed at about 8:00 o'clock each morning to favor drying off of the plants and to stimulate their growth. During rainy weather judgment must be used as to whether or not it is best to leave the covers in place during the day.

How Often to Fumigate. When started, treatments should be continued nightly.

When to Stop Fumigation. Fumigation may be discontinued either when all danger from infection is passed or when sufficient seedlings have been transplanted to the field.

PARADICHLORBENZOL FUMIGATION

Paradichlorbenzol (Paradichlorbenzene). This chemical is commercially known as "P. D. B." It has been used for a long time to control peach tree borers. Since it consists of crystals it is easy to handle. Crystals of P. D. B.* are packaged by manufacturers in 100 and 200 pound lots, and in these quantities its cost ranges from 12 to 15 cents per pound. When packaged in one pound cans, available at drug stores, it is more expensive. Only a limited number of tests to control blue mold have been made with this chemical, but it is worthy of careful consideration because it has given very promising results. Whether fumigation with P. D. B. is preferable to the other methods of treatment has not yet been established and this information can only be gained by additional tests.

Preparation of Beds for Fumigation with P. D. B. Experiences of the past season indicate that best results with P. D. B. may be secured under the following conditions:

- (1) The seed beds should not be more than two yards wide, preferably located where there is protection from sweeping winds.
- (2) The cloth used for covers during fumigation should be a heavy sheeting, having 50 to 60 threads each way per inch.
- (3) One ounce of P. D. B. per day should be applied for each four to five square yards of seed bed area.

The vapors of P. D. B. are heavier than air. This fact limits their spread in the seed bed and constitutes one of the reasons why narrow beds are preferable. Strips of board fastened along each side of narrow beds will serve for shelves on which to scatter the P. D. B. (Fig. 7). The shelves should be as high as possible above the ground to permit the vapors to spread properly. Special platforms as shown in Fig. 7, may be used instead of shelves. If wider beds are used the shelves or platforms should be placed in such a way that the most distant points in the bed are within three or four feet of a shelf.

The crystals of P. D. B. slowly evaporate when exposed to the air and tend to form a crust on the shelves. For best results this crust should be broken up when replenishing the supply each night. The crystals should be protected from rain even though they do not dissolve readily in water.

The use of covers of close weave is advisable in order to confine a sufficient strength of P. D. B. vapor within the beds. Ordinary tobacco cloth doubled several times has been used effectively in a few instances. In these cases the cloth was kept wet at night, and as an additional precaution twice the recommended amount of P. D. B. crystals was used.

Experience to date indicates that the supply of crystals should be replenished every night. If the disease is not present in the bed when fumigation is begun

*Several companies are engaged in the manufacture of P.D.B. Their addresses can be supplied by county agents and other agricultural specialists.

and heavy covers are used, one ounce of crystals for each four to five square yards of seed bed area should be sufficient to give satisfactory control. If blue mold is already present in the bed when fumigation is started, then two or three times this amount of crystals should be distributed along the shelves for two or three successive nights. This increased dosage should check the disease, after which the regular amount of crystals should be applied.

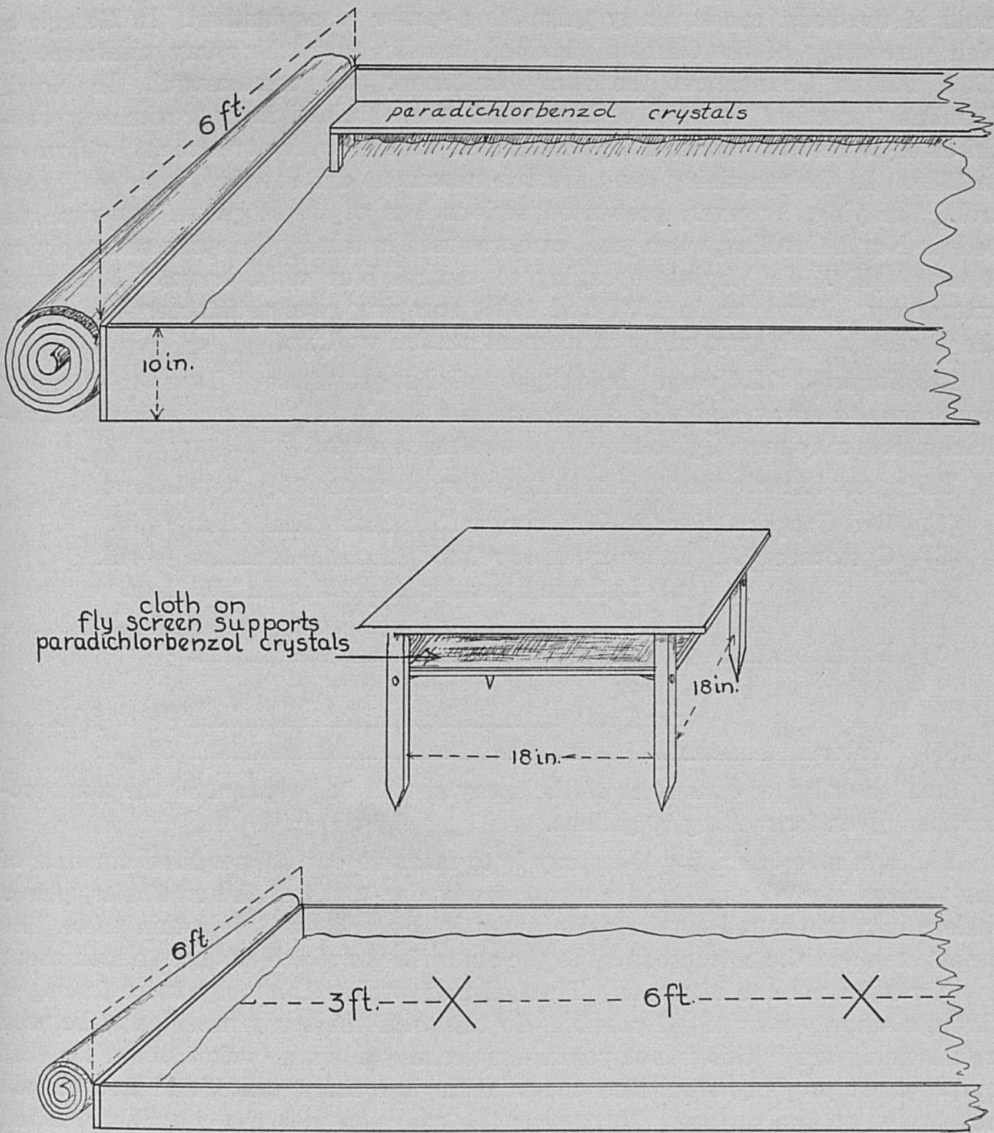

Fig. 7.—Plan of seed-beds when P. D. B. is used in fumigation. The crystals are distributed on shelves or on stands placed in a line down the center of the bed.

SPRAY TREATMENT

Extensive experimental tests have been made with a wide variety of spray materials to determine their value in control of blue mold. Of those tested, a mixture composed of red copper oxide, emulsified cottonseed oil, and water, has in many cases given beneficial effects, but it can not be depended on for uniformly satisfactory control under all conditions.

The spray treatment should not be expected to prevent infection of seedlings with the blue mold parasite under conditions exceptionally favorable for infection and it has little to no curative value. A general outbreak of blue mold usually occurs on sprayed beds during epidemic years. This outbreak, however, is ordinarily a few days later than on unsprayed beds and is usually of shorter duration. Benefits to be expected from the spray treatment are: (1) partial prevention of loss of stand of seedlings, and (2) a shortened period of active development of mold in the beds, consequently permitting earlier transplanting. In Georgia a high percentage of the farmers obtained benefits from the spray treatment in 1938, but in Connecticut the spray treatment was unsuccessful. In North Carolina "practical" control of blue mold was obtained in approximately two-thirds of 30 result demonstrations conducted with the spray treatment by farmers in 1938. In the remaining one-third the treatment did not give "practical" control. Spraying, however, prevented serious loss of seedlings, on experimental beds in North Carolina, when great care was used in mixing the spray and applying it thoroughly. In Virginia spraying to control blue mold has not been used extensively. However, in 1937 and 1938, spraying gave satisfactory control of the disease in beds sprayed by experiment station workers.

Red Copper Oxide Spray. It is suggested that growers who have the necessary equipment to spray and who appreciate the fact that wide variations in beneficial effects may result, give the spray treatment a trial.

The spray formula that has been tested most extensively is as follows:

(1) Red Copper Oxide (85-90% copper).....		½ lb.
(2) Cottonseed Oil (either crude or refined).....		½ gal.
	(a) Lethane Spreader.....	1 qt.
	or	
(3) Emulsifier.....	(b) Orvus*.....	½ to ¾ pt.
	or	
	(c) Dreft*.....	½ to ¾ lb.
(4) Water.....		50 gal.

Smaller or larger quantities of the spray should be prepared in the same proportions given for making 50 gallons.

The first step in mixing the spray is to measure out the required amounts of the various ingredients. Add approximately one-tenth of the emulsifier, plus a little water, to the red copper oxide and stir this mixture into a thin paste. As a next step add the cottonseed oil to the emulsifier to which has been added about five times its volume of water. Then emulsify this mixture by twice forcing it through a spray nozzle. If possible, do this with the spray machine to be used in the field; but if this is not possible, purchase a small bucket pump for that purpose. If properly emulsified the mixture is creamy white, and free oil will not collect on the surface. Next pour the emulsion into the container selected for mixing the spray, to which has been added about three-fourths of the required amount of water for the final mixture. Add the red copper oxide paste and bring the volume of the mixture up to the desired amount with water. The spray mixture should be used as soon as possible after mixing. *Do not attempt to keep the spray overnight.*

*One-half to three-fourths of a pint of Orvus or one-half to three-fourths of a pound of Dreft is sufficient to emulsify one-half gallon of cottonseed oil in soft water but slightly larger quantities are needed if hard water is used. Dreft is sold as a washing powder by the larger grocery stores.

To avoid preparing the mixture several times for one spraying of the beds, it is suggested that those using small spray machines (5 to 10 gallons) obtain a 50 to 60-gallon barrel, mix the spray in it, and then transfer the mixture to the spray tank as needed. Before refilling small spray machines, thoroughly stir the spray mixture. When not more than 50 gallons of the mixture will be required to cover the beds only one mixing will be required, provided all the spray be used on the day mixed.

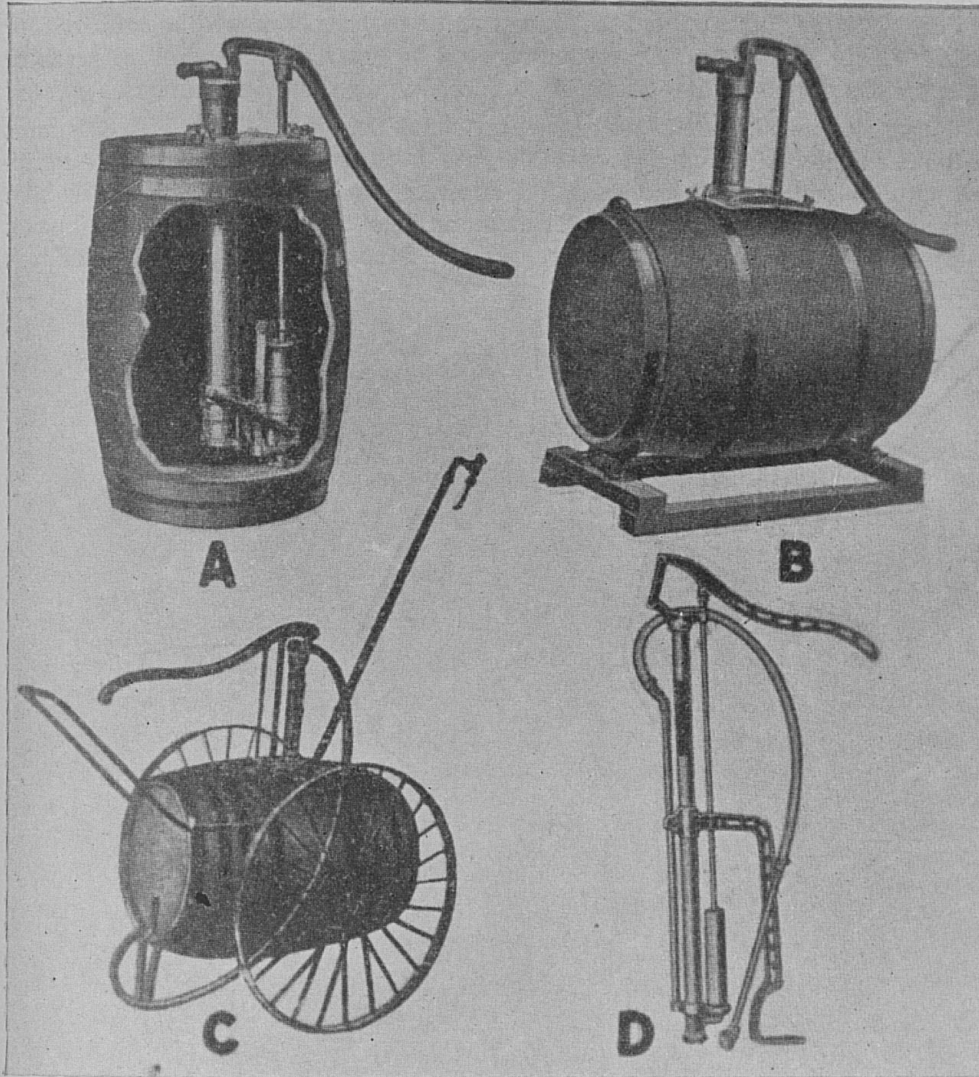

Fig. 8.—Kinds of spray outfits found to be most satisfactory for spraying tobacco seedlings.

When to Start Spraying. The use of red copper oxide spray is a preventive treatment. For the treatment to be effective, therefore, it must be started before a general outbreak of the disease is due to occur. Starting the treatment after the mold has appeared in the bed usually results in very unsatisfactory control. The first two or three spray applications may be applied through the covers. The covers should be removed when making subsequent applications.

Frequency of Applications. The spray should be applied twice weekly, except when the plants are very small. Stunting may result from the early applications. If severe stunting develops, less spray should be applied or the number of applications should be reduced. The spray should be continued until the seedlings are transplanted, the total number of applications usually varying from eight to sixteen.

Amount of Spray to Apply. The quantity of spray required to cover 100 square yards of bed will increase as the season progresses and as the plants increase in size. For the first application, from two to three gallons will be sufficient for each 100 square yards. This amount should be gradually increased to seven or eight gallons per 100 square yards for the last two or three applications.

Spray Equipment. A barrel type spray machine, illustrated in Fig. 8, is most suitable. It should develop at least 100 pounds of pressure. It should be equipped with at least 25 feet of hose, a five or six foot rod with a cut-off at the base of the rod, and a disc type nozzle set at an angle of about 45 degrees. A bucket pump outfit or a compressed air sprayer is of doubtful value since the seedlings must be well covered with spray.