

HOUSEHOLD EQUIPMENT

is care and simple repair



ire and
agricul-
May 8

M-6-43

ACKNOWLEDGEMENT

This publication was originally prepared by the Agricultural Extension Service, University of Tennessee, with the Agricultural Engineering Development Division of the Tennessee Valley Authority cooperating.

FUSES - CORDS - PLUGS Page 4

SMALL APPLIANCES Page 8

REFRIGERATORS Page 18

RANGES Page 23

WASHING MACHINES Page 29

KITCHEN UTENSILS Page 32

PRESSURE COOKERS Page 34

SIMPLE PLUMBING Page 35

UNIVERSITY OF KENTUCKY
COLLEGE OF AGRICULTURE AND HOME ECONOMICS,
EXTENSION SERVICE . . . LEXINGTON

Circular 391

September, 1943

Cooperative Extension Work in Agriculture and Home Economics: University of Kentucky, College of Agriculture and Home Economics, and the United States Department of Agriculture, cooperating. Thomas P. Cooper, Director. Issued in furtherance of the Acts of Congress of May 8 and June 30, 1914.

THE CARE AND SIMPLE REPAIR OF HOUSEHOLD EQUIPMENT

Prepared by
AGRICULTURAL ENGINEERING
AND HOME MANAGEMENT SPECIALISTS

Every family should plan to make household equipment last as long as possible. Daily care and needed repair of equipment will determine the length of its usefulness.

This publication has been prepared to help families properly care for equipment, as well as to locate minor troubles and make simple repairs. Some mechanical difficulties will develop which are not covered in this publication and for these repairs it is recommended that the services of a trained repairman be secured.

Caution: Electric appliances and equipment should always be disconnected before cleaning or making simple repairs.

HOME TOOL KIT

The following tools will be helpful in making simple repairs at home; Fig. 1.

Screw Drivers	Pliers	Ice Pick
Monkey Wrench	Hammer	Flat File
Knife	Ruler	Round File
Putty Knife	Brush	Whet Stone
Nails	Solder	Oil Can
Tacks		

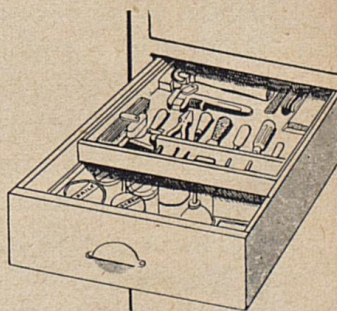

Fig. 1.

HOW TO USE THE FOLLOWING INSTRUCTIONS

1. Refer to the specific trouble. The trouble may be due to one cause or to a combination of several.
2. Begin with the first cause listed. Check over that part of the appliance directly concerned. Either a repair or a replacement may be necessary. Try the appliance after making repair or replacement.
3. Take each of the other causes in order listed. Treat them as described until the appliance operates satisfactorily.

FUSES - CORDS - PLUGS

FUSES OR CIRCUIT BREAKERS

The wiring circuits in homes and farm buildings are protected by either fuses or circuit breakers. When fuses blow or circuit breakers trip - the trouble is not in the fuse or circuit breaker, but some place in the cord, plug, equipment, wiring system, or the circuit is overloaded.

Locate the trouble and correct it before replacing fuse or resetting circuit breaker.

1. **PLUG FUSES** are round and screw into the fuse socket. Fig. 2
2. **NON-TAMPERABLE FUSES** are round and the adapter screws into the fuse socket. Once the adapter is in, it locks and cannot take a fuse any larger than the rating of that particular adapter.
3. **TIME DELAY FUSES** are made to carry 100 percent overload for about 30 seconds but will blow on overloads lasting a few minutes. This type fuse is desirable when there are several motor-driven appliances in the home.
4. **CARTRIDGE FUSES** are generally used for the main circuit - range and water heater. Fig. 2 Top.

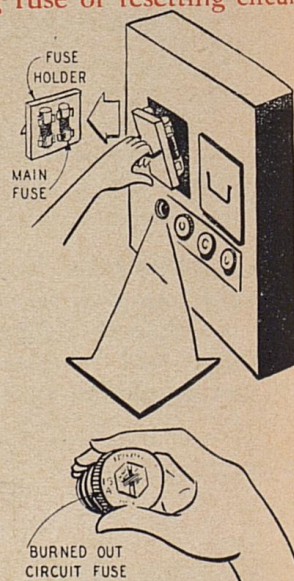

Fig. 2

Replacing a Fuse

- a. Stand on dry board or floor. Fig. 3.
- b. Open main switch. Fig. 2 or 3.
- c. Correct trouble causing fuse to blow.
- d. Remove blown fuse. Fig. 2.
- e. Replace with correct size.
- f. Close main switch.



Fig. 3

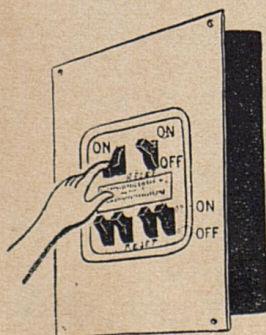

Fig. 4

5. **CIRCUIT BREAKER:** The circuit breaker takes the place of fuses and a switch.

Resetting Circuit Breaker

- a. Move handle to "OFF" position. Fig. 4
- b. Push handle past "OFF" position. Fig. 4
- c. Return handle to "ON" position. Fig. 4

fuses - cords - plugs

Testing for Trouble in the Electric Circuit

1. Disconnect all appliances.
2. Open main switch.
3. Remove blown fuse.
4. Insert a light bulb. Fig. 5.
5. Close the main switch.

If the bulb burns, a short exists in the wiring system. If bulb does not burn, the trouble will be found in the plug, cord, or equipment.

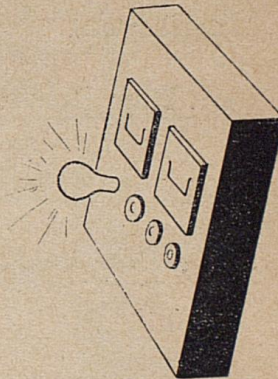

Fig. 5

Testing Cords and Plugs

1. Plug cord into convenience outlet. Fig. 6
2. Insert trouble lamp (weatherproof socket and bulb) into appliance plug. Fig. 6. If the lamp does not burn, the cord or plugs need to be repaired.
3. Flex cord (Fig. 7) to locate broken wires.

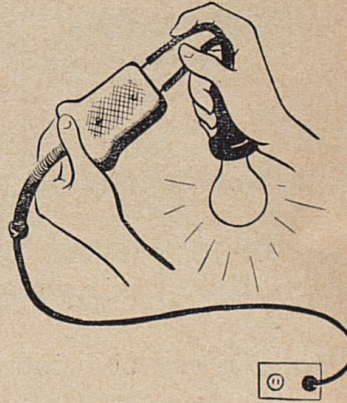

Fig. 6

PLUGS AND CORDS

Types of Plugs

Plug for Convenience Outlet: May be bakelite (a and b), rubber (c), or hard rubber metal covered (d). Fig. 8



Fig. 8

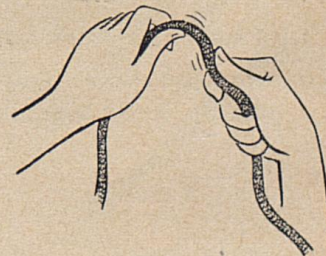

Fig. 7

Appliance Plug: Used on heat appliances, such as iron, roaster, and waffle iron. Fig. 9

These are commonly found in three sizes.

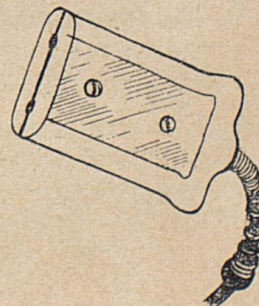

Fig. 9

fuses - cords - plugs

Types of Cord

Braided Cords: Commonly used for fans, lamps and sewing machines. Fig. 10.

Light Duty Rubber Covered Cord: Used on same equipment as braided cords.

Heating Appliance Cords: Used for roasters, hotplates, irons and all heat appliances. Fig. 11.

Heavy Duty Rubber Covered Cord: Used for vacuum cleaner and washing machines; resistant to moisture and mechanical injury. Fig. 12.



Fig. 10

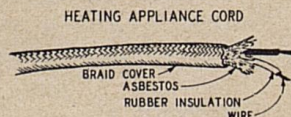

Fig. 11



Fig. 12

Attaching Convenience Outlet Plug to Cord

1. Pass cord through cap. Fig. 13.
2. Follow steps indicated in figure 13 and make knot.
3. Bind end of fabric covering with a piece of thread.
4. Remove $\frac{1}{2}$ -inch of rubber insulation. Fig. 13.
5. Twist strands of wire tightly.
6. Connect wire around screw in direction in which screw tightens. Fig. 13.

Be sure that insulation comes to screw terminal but does not extend under it.

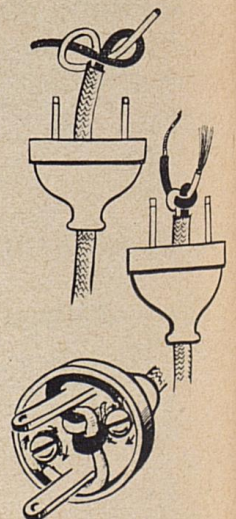

Fig. 13

Attaching Appliance Plug to Cord

1. Disconnect the cord from the convenience outlet before repairing.
2. Disassemble plug on end of cord where it connects to appliance.

Notice carefully the placement of each part.

3. Remove $2\frac{1}{2}$ -inches of outer covering. Fig. 14-a.

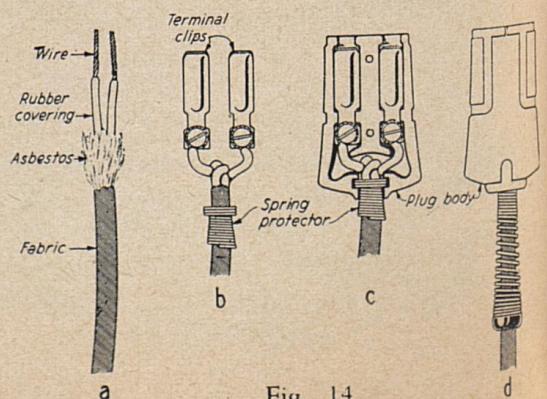

Fig. 14

fuses - cords - plugs

4. Run cord through spring protector. Fig. 14-b.
5. Fit wires into one-half of plug temporarily to determine how long the individual wires should be. Cut them to proper length.
6. Bind end of fabric covering with a piece of thread.
7. Remove about $\frac{1}{2}$ -inch rubber insulation from end of each wire. Fig. 14-a.
8. Make terminal connections. Fig. 14-b.
9. Place terminal clips and spring into one-half of plug. Fig. 14-c.
10. Fit sides of plug together and replace screws or clamps.
11. Inspect convenience outlet plug at other end of cord, and test connections. Figures 13 and 6.

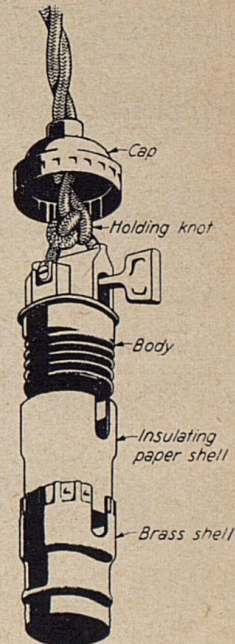

Fig. 15

Attaching Socket to Cord

1. Follow directions shown in Fig. 15 to attach socket.

Splicing Cords

1. By cutting out the broken piece and inserting a cord connector. Fig. 16.
2. By cutting out the frayed or broken parts of the cord, splicing and soldering. Tape each wire with rubber tape and then both wires with friction tape. Fig. 17.

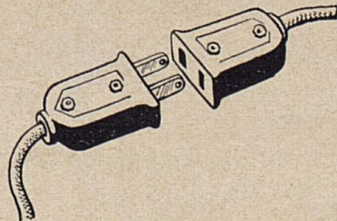

Fig. 16

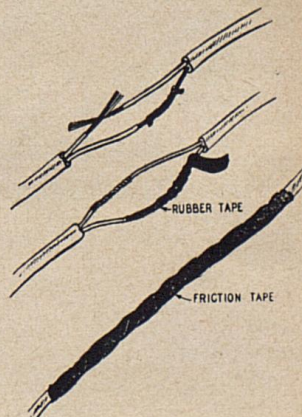

Fig. 17

Adjusting Plug Prongs

Plug prongs sometimes do not fit the convenience outlet properly. The prongs may be spread to fit tightly into the receptacle. Fig. 18.

Care of the Cord

1. Store in cool and dry place.
2. Do not bend sharply.
3. To disconnect, grasp plug instead of cord.
4. Keep oil and grease away from cords.

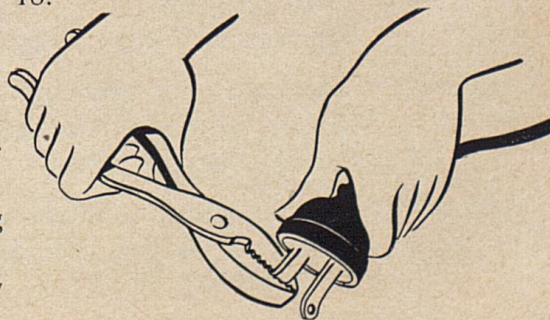

Fig. 18

SMALL APPLIANCES

Small electrical appliances are divided into two groups: (1) Small Heat Appliances and (2) Motor Driven Appliances.

Small Heating Appliances

Heating coils on small appliances are of two general types: Totally enclosed coils, which cannot be repaired in the home, and open type coils in which a temporary repair can sometimes be made.

Repairing Open Coil Heating Elements

There are two methods commonly used in repairing a heating coil. Select the method which fits your needs.

1. Reattaching the broken coil to the terminal. This repair can be made only when the break is close to the terminal. Fig. 19.
 - a. Clean the wire at least $\frac{1}{2}$ -inch from end.
 - b. Fasten around terminal in direction screw or nut tightens. Fig. 19.
2. Fastening the broken ends together with a metal sleeve. Fig. 20.
 - a. Clean the broken ends.
 - b. Place broken ends in sleeve.
 - c. Crush the sleeve on the wire with pliers.

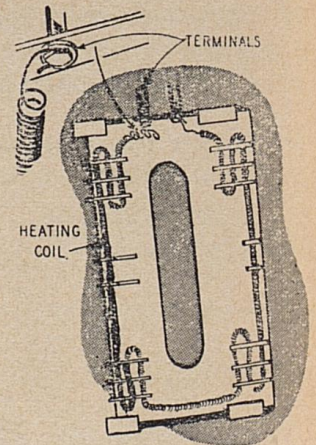

Fig. 19

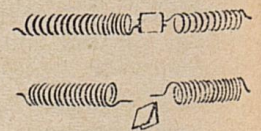

Fig. 20

HAND IRON

1. Iron Does Not Heat

1. *Cause:* Loose connection at wall outlet; fuse blown; cord or plug needs repairing.

Remedy: See page 4, Cords - Plugs - Fuses.

2. *Cause:* Thermostat not operating.

Remedy: Return to dealer, serviceman, or manufacturer for repair.

3. *Cause:* Heating element burned out.

Remedy: Return to dealer, serviceman, or manufacturer for repair.



Fig. 21

Small Appliances

II. Iron Slow to Heat

1. *Cause:* Connected to light socket or extension cord.
Remedy: Connect the iron directly to wall outlet.

III. Iron Overheats

1. *Cause:* Thermostat set too high.
Remedy: Set thermostat to lower heating.
2. *Cause:* Thermostat operating improperly.
Remedy: Return to dealer, serviceman or manufacturer for repair.

Care, Cleaning and Operation

1. The iron will sometimes stick to clothing. This is particularly true if too much starch has been used. A small amount of salt in the starch will help to keep the iron from sticking. The iron may stick to rayon or synthetic fabrics because the iron is too hot.
2. The sole of the iron may be cleaned by rubbing it in salt sprinkled on waxed paper, or on paraffin while hot. Polish with a dry cloth.
3. Disconnect the iron by removing plug from the wall outlet - never by removing plug at the iron. Fig. 22.
4. Never put iron in water.
5. Most electric irons are designed to rest on their heels. If a flat stand is used the heat may rise and damage the handle.
6. Never wrap the iron cord around the iron while hot. Heat is injurious to rubber and will shorten the life of the cord.
7. Keep the iron in a dry place when not in use.

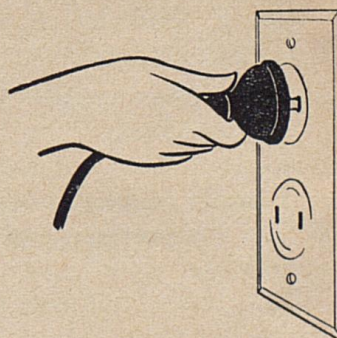

Fig. 22

HEATING PAD

I. Heating Pad Does Not Heat

1. *Cause:* Fuse blown, cord or plug needs repair.
Remedy: See page 4. Fuses - Cords - Plugs.
2. *Cause:* Broken switch or loose contacts in switch.
Remedy: If switch is broken, replace it. If contacts are sprung or worn they can be repaired as shown in Fig. 23.

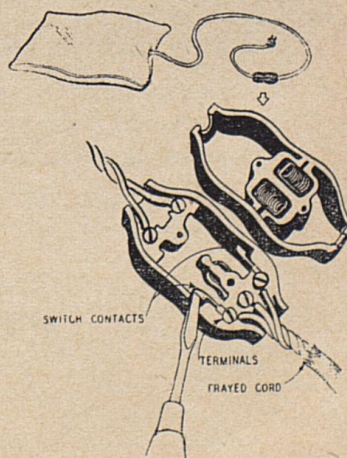

Fig. 23

Small Appliances

Care, Cleaning and Operation

1. Keep heating pad dry.
2. Do not bend or fold more than necessary. The heating pad is made of small low-temperature heating wire placed in an asbestos blanket. Bending or folding pad will eventually break heating element.
3. Place the heating pad in a pillow case or keep in cover provided to protect the pad.
4. Never put pins through heating pad as it may short-circuit the heating coils or break them.
5. Never store pad in folded position.

HOTPLATES

1. Hotplate Will Not Heat

1. *Cause:* Fuse blown, cord or plug needs repair.

Remedy: See page 4, Fuses - Cords - Plugs.

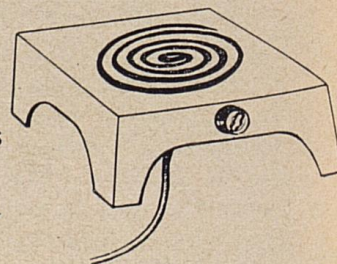

Fig. 24

2. *Cause:* Broken or burned out heating element. Fig. 24.

Remedy: See repair of heating elements, page 8.

Care, Cleaning and Operation

1. Never put hotplate in water.
2. Clean metal part of hotplate with damp cloth. Whiting (page 32) and soap may be used to remove stains and greases.
3. If excessive greases or syrups are spilled on heating unit: First, wipe off with a dry cloth; second, turn the switch to high position and allow the remaining greases and syrups to burn off the unit.
4. Burned particles on the heating element may be removed by using a soft brush.

PERCOLATOR

1. Percolator Will Not Operate

1. *Cause:* Fuse blown, cord or plug needs repair.

Remedy: See page 4, Fuses - Cords - Plugs.



PERCOLATOR FUSES

Fig. 25

Small Appliances

2. **Cause:** Percolator fuse blown. Fig. 25.

Remedy: Examine bottom of percolator for fuse. It may be necessary to remove bottom plate and replace fuse. Fig. 26.

3. **Cause:** Percolator valve or pump may be clogged.

Remedy: Clean the valve or stem by forcing water through it or use a small round brush. Fig. 26.

4. **Cause:** Valve not seated in heating well.

Remedy: Clean heating well and valve.

5. **Cause:** Percolator heating element burned out.

Remedy: Return to serviceman, dealer, or manufacturer for replacement.

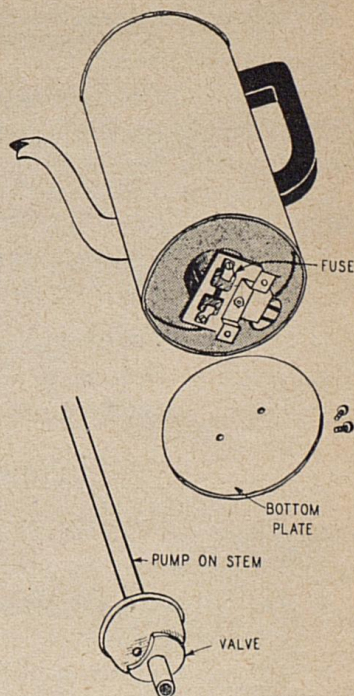

Fig. 26

Care, Cleaning and Operation

1. Bitter coffee may be caused by allowing coffee to stand in percolator, using stale coffee, and allowing coffee to percolate too long.
2. The percolator should be washed occasionally with water to which has been added one tablespoon of vinegar or soda to six cups of water and allowed to percolate ten minutes to remove any stale odors.
3. The inside of the percolator should be washed with soap and water. The outside may be cleaned with silver polish or whiting and soap.
4. Coarse scouring powder should not be used.

ROASTER

I. Roaster Is Not Heating

1. **Cause:** Thermostat set on "OFF" position.

Remedy: Set Thermostat to desired baking temperature. Fig. 27.

2. **Cause:** Fuse blown, cord or plug needs repair.

Remedy: See page 4, Fuses - Cords - Plugs.

II. Roaster Does Not Heat Properly

1. **Cause:** Thermostat set too low.

Remedy: Set thermostat at higher position.

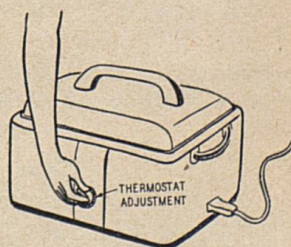

Fig. 27

Small Appliances

- Cause:* Connected to drop cord or long extension cord.
Remedy: Connect to wall outlet.
- Cause:* Lid may be warped or sprung.
Remedy: Return to dealer, serviceman, or manufacturer for repair.

III. Roaster Gets Too Hot

- Cause:* Thermostat set too high.
Remedy: Place thermostat at lower setting.
- Cause:* Thermostat operating improperly.
Remedy: Return to dealer, serviceman, or manufacturer for replacement.

Care, Cleaning and Operation

- Clean the outside of the roaster with damp cloth. Whiting (page 32) and soap may be used to remove grease spots.
- Do not place the roaster in water for cleaning. The inset pan can be washed in water.
- Do not connect to a drop cord or extension cord because the wires are of too small size for satisfactory heating. Connect the roaster directly to a wall outlet.
- Do not use roaster on a circuit when another heating appliance is in use.
- Store the roaster in a dry place.

TOASTER

There are three general types of toasters: automatic, semiautomatic, and nonautomatic.

The troubles and remedies given here may apply to all toasters but do not include mechanical troubles found in automatic or semiautomatic toasters.

I. Toaster Will Not Heat

- Cause:* Fuse blown, cord or plug needs repair.
Remedy: See page 4, Fuses - Cords - Plugs.
- Cause:* Heating element broken or burned out.
Remedy: Return to dealer, serviceman or manufacturer for repair.

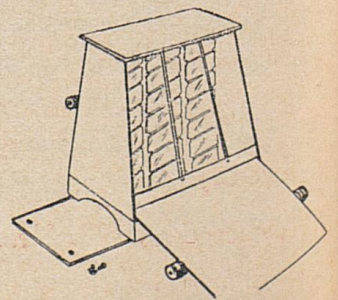

Fig. 28

Small Appliances

Care, Cleaning and Operation

1. Disconnect toaster plug from receptacle before cleaning.
2. Never put toaster in water to clean. Use a damp cloth—not wet—to wipe off inside. Whiting (page 32) and soap or any mild abrasive may be used to clean stains or grease spots from metal parts of toaster. A soft bristle brush should be used for cleaning bread crumbs from inside. It may be necessary to remove bottom plate. Fig. 28.
3. Do not wrap cord around toaster while the toaster is hot.

WAFFLE IRON

I. Waffle Iron Will Not Heat

1. *Cause:* Fuse blown, cord or plug needs repair.
Remedy: See page 4, Fuses - Cords - Plugs.

2. *Cause:* Connecting cord between upper and lower element broken.
Remedy: Disassemble and repair in the same manner as any other cord Fig. 29.

3. *Cause:* Heating coil burned out. Fig. 29.
Remedy: See repair of heating element, page 8.

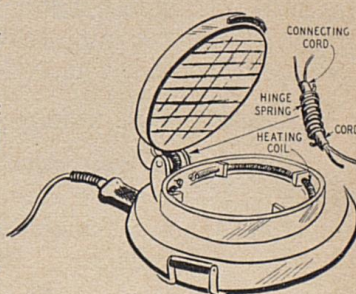

Fig. 29

II. Waffle Iron Overheats (automatic type)

1. *Cause:* Thermostat damaged or stuck.
Remedy: Return to dealer, serviceman, or manufacturer for repair.

Care, Cleaning and Operation

1. Batter which is too thin may cause waffles to burn.
2. Grids may be cleaned by placing a paper napkin soaked with ammonia between them and leaving it overnight. Clean with steel wool and whiting (page 32)
3. Waffles will sometimes stick on new grids or after the grids have been cleaned. To eliminate this trouble grids may be greased with unsalted fat and iron preheated thoroughly.
4. Waffle iron should be left open until cool.

SMALL MOTOR OPERATED APPLIANCES

I. Motor Does Not Start

1. *Cause:* Blown fuse, cord or plug needs repair.
Remedy: See page 4, Cords - Plugs - Fuses.

Small Appliances

2. *Cause:* Motor damaged.

Remedy: Return to dealer, serviceman, or manufacturer for repair.

II. Motor Runs Hot

Motors, when in constant use, may operate at a temperature hot enough to be uncomfortable to the touch, but not smoking.

1. *Cause:* Motor bearings need lubrication.

Remedy: Turn motor shaft by hand. See that it turns freely and is not stuck. Lubricate according to directions listed under each appliance in this publication.

2. *Cause:* Motor overloaded.

Remedy: If the motor on a vacuum cleaner runs hot, clean and empty the bag.

If the motor on a mixer runs hot, the batter is too stiff.

3. *Cause:* Low voltage.

Remedy: If long runs of small wire are being used, remove and plug directly into a house lighting circuit. If this fails to remedy the trouble, ask your power distributor to check your house voltage.

4. *Cause:* Dust or dirt in the motor windings, especially with household fans.

Remedy: Blow and wipe the dust out of the motor; avoid over-oiling.

5. *Cause:* Motor windings damaged or other internal trouble.

Remedy: Return to dealer, serviceman, or manufacturer for repair.

III. Motor Operates But Does Not Come Up To Full Speed

1. *Cause:* Overload.

Remedy: See Item 2 above.

2. *Cause:* Low voltage.

Remedy: See Item 3 above.

3. *Cause:* Motor in need of lubrication.

Remedy: Lubricate. See directions listed under each motor-driven appliance.

4. *Cause:* Motor damaged.

Remedy: Return to a serviceman, dealer or manufacturer for repair.

Small Appliances

VACUUM CLEANER

There are two general types of cleaners, the cylinder type, Fig. 30, and upright type, Fig. 31. The cylinder type is always a straight suction cleaner. The upright may have a revolving brush or roll (Fig. 32) to sweep or vibrate the rug.

1. Cleaner Refuses to Pick up Dirt

1. *Cause:* Cleaner bag may need emptying.

Remedy: Empty bag, turn wrong side out, and brush or clean.

2. *Cause:* Improper adjustment of cleaner nozzle.

Remedy: Find the nozzle adjustment on your cleaner, Fig. 31, (some cleaners do not have an adjustment). Adjust so that a quarter slides easily between cleaner nozzle and rug. On cleaners with a rotating brush or roll, the clearance should be the thickness of a half dollar. Fig. 32.

3. *Cause:* Improper adjustment of cleaner brush.

Remedy: Hold machine with nozzle up, lay a ruler or piece of stiff cardboard over the nozzle. The bristles should not quite touch the ruler; a space of 1/32-inch is desirable. The adjustment is usually made by moving a pin, screw or lever at each end of the brush. Fig. 33.

4. *Cause:* Broken belt or belt not revolving.

Remedy: Examine the belt. Fig. 32. Make sure it is around both the brush and motor shaft and is not tangled with hair and strings. If after cleaning the brush it still will not turn with the motor, the belt is probably stretched and should be replaced with a new belt. To replace belt: Fig. 32.

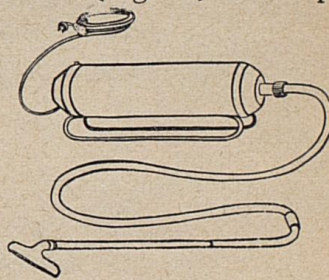

Fig. 30

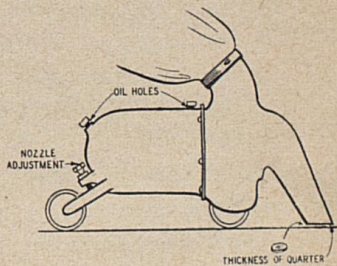

Fig. 31

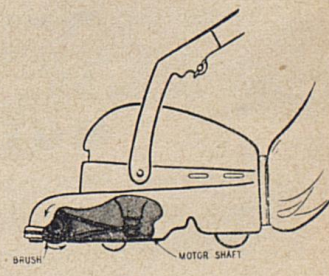

Fig. 32

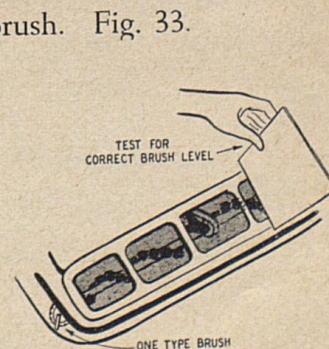

Fig. 33

Small Appliances

- a. Slip belt off motor shaft.
- b. Remove brush and belt from cleaner.
- c. Slip new belt over brush.
- d. Place brush back in cleaner.

Caution: Be sure brush rotates as shown in Fig. 32. If brush rotates in the opposite direction, remove belt from motor shaft, twist in the opposite direction, and replace.

II. Motor Does Not Operate

1. See motor trouble. Page 13.

Care, Cleaning and Operation

1. Lubrication: Most cylinder type cleaners Fig. 30 and many upright cleaners Fig. 32 have bearings which are sealed and packed with grease at the factory. These types require no lubrication but should be inspected at least yearly by a competent serviceman. If any unusual noise develops in these cleaners they should immediately be taken to a serviceman, dealer, or manufacturer for inspection.

Some upright cleaners of the type shown in Fig. 31 have 2 oil holes located as shown. Oil these cleaners with 3 or 4 drops of electric motor oil monthly. An occasional drop of oil on the wheel bearings of the cleaner is desirable.

2. Do not use the cleaner to pick up metal objects such as pins.
3. Empty the bag after each general cleaning.
4. Avoid picking up strings as these may wind around the brush or roll and cut the belt.

HOUSEHOLD FANS

Household fans are made in a variety of types and sizes. There is little to get out of order provided they are given proper care and lubrication.

I. Fan Vibrates Excessively

1. Cause: Bent or sprung blade.

Remedy: Test for a sprung blade as shown in Fig. 34. If metal, it may be sprung back into position.

2. Cause: Motor bearings damaged.

Remedy: Return to serviceman, dealer or manufacturer for new bearings.

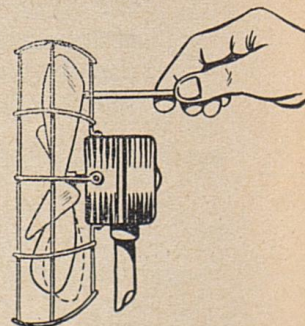

Fig. 34

Lubrication of Fan Motors

There are usually two points of lubrication on fans. These are located at each end of the motor shaft.

Small Appliances

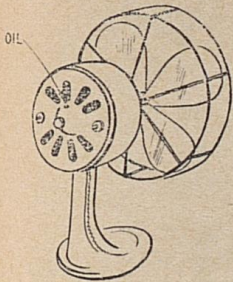

Fig. 35

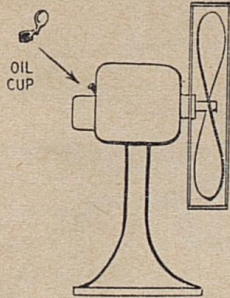

Fig. 36

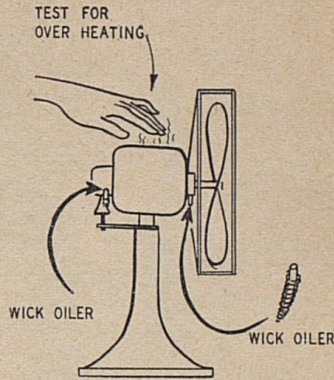

Fig. 37

1. With bearings of the type shown in Fig. 35, use 2 or 3 drops of electric motor oil in each bearing daily.
2. If your fan is of the type shown in Fig. 36 and is in constant operation it should be lubricated at least weekly with 2 or 3 drops of electric motor oil.
3. Shown in Fig. 37 is a fan which contains wick oilers. These oilers or cups should be filled yearly with vaseline or a light grade of cup grease.

MIXER

I. Motor Does Not Operate

1. See motor troubles. Page 13.

II. Beaters Strike Mixing Bowl

1. **Cause:** Beaters not placed firmly in their sockets.

Remedy: Push the beaters up until they are firmly in their sockets.

2. **Cause:** Improper adjustment of the motor head.

Remedy: Most mixers are provided with an adjustment to raise and lower the beaters in the mixing bowl. Fig. 38. Find this adjustment on your mixer, loosen the lock nut and turn the screw until the beaters just touch the bowl. Tighten the lock nut.

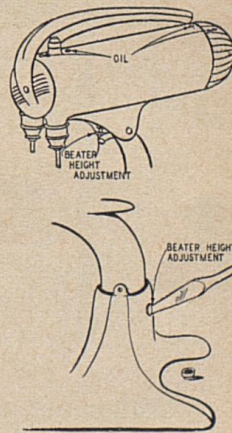

Fig. 38

Care, Cleaning and Operation

1. **Lubrication:** Many mixers have sealed bearings which are packed with grease at the factory. Other mixers, as shown in Fig. 38, require lubrication. If the mixer is used frequently, it should be oiled every two weeks with 3 or 4 drops of light machine oil. If the mixer is not used often, it should be oiled once a month.

The front cover should be removed at six-month intervals and the grease in the gear case examined. The old grease should be cleaned out and new grease added if necessary.

2. The motor should be wiped off with a damp cloth after use. Care should be taken not to get water in the oil holes or electrical parts.
3. The motor should be covered with a cloth or paper, when not in use.

REFRIGERATORS

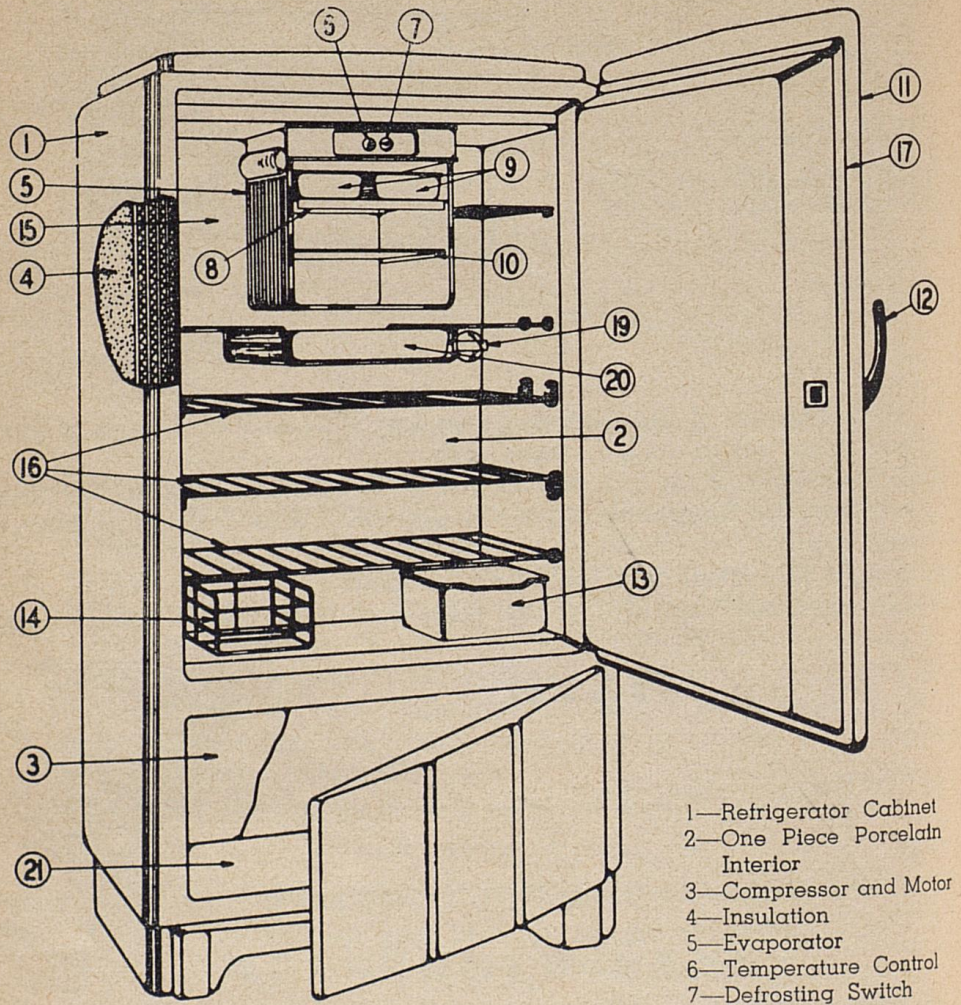

Fig. 39

- | | | |
|--------------------------------|------------------------------|-----------------------|
| 1—Refrigerator Cabinet | 13—Vegetable Crisper | 17—Rubber Door Gasket |
| 2—One Piece Porcelain Interior | 14—Fruit Basket | 19—Interior Light |
| 3—Compressor and Motor | 15—Shelf Space for Tall Jars | 20—Chiller Tray |
| 4—Insulation | 16—Sliding Shelves | 21—Storage |
| 5—Evaporator | | |
| 6—Temperature Control | | |
| 7—Defrosting Switch | | |
| 8—Refrigerated Shelf | | |
| 9—Freezing Trays | | |
| 10—Removable Shelf | | |
| 11—Insulated Door | | |
| 12—Finger Tip Action | | |

1. Motor Will Not Run

1. *Cause:* Fuse blown; loose connection at wall outlet or motor; cord or plug needs repair.

Remedy: See page 4, Fuses - Cords - Plugs.

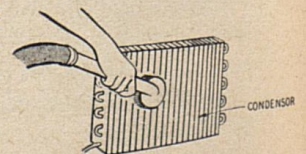

Fig. 40

Refrigerators

II. Motor Runs Too Much

1. *Cause:* Condenser dirty.

Remedy: Clean condenser once or twice a year with a long handled brush or vacuum cleaner attachment. Fig. 40. Condenser is usually located at the top, back (Fig. 41), or at the bottom (Fig. 46) of the refrigerator. If necessary, pull refrigerator out from wall.

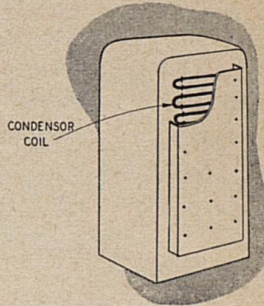

Fig. 41

Caution: Always disconnect refrigerator from power supply before cleaning condensers.

2. *Cause:* Refrigerator overcrowded.

Remedy: Remove foods that do not need refrigeration, such as jams and jellies. See that dishes are not crowded against each other or against the sides of the refrigerator. Do not place hot foods in the refrigerator.



Fig. 42

3. *Cause:* Door leaking air. Test by closing the door on a dollar bill or a piece of paper of the same thickness. Fig. 42. If you can pull the paper out easily, there is a poor fit at this point. Test at several points around the door.

Remedy: a. Adjust the door latch. Fig. 43. On some models this may require a serviceman.

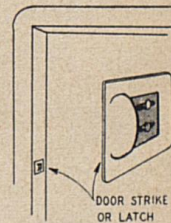

Fig. 43

- b. Door may need a new rubber gasket. Fig. 44. The old gasket can usually be taken off by removing the screws around the door edges.

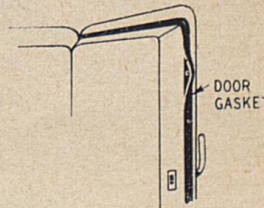

Fig. 44

4. *Cause:* Door opened too frequently or allowed to stand open.

Remedy: Have all foods ready to place in the refrigerator before opening the door. Locate the refrigerator so that door opens conveniently to a nearby work surface. Fig. 45. Close the door immediately after the foods are placed inside.

Refrigerators

5. *Cause:* Refrigerator improperly located.

Remedy: See that refrigerator is not too close to a coal or wood stove, or too close to the wall or cabinets. Allow a 12-inch space above the refrigerator and a 4-inch space at the back and sides. Fig. 45.

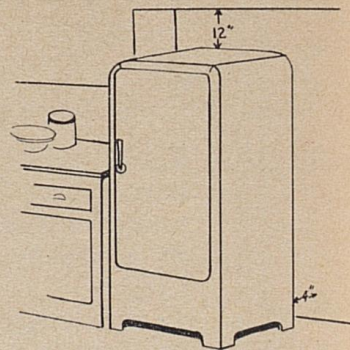

Fig. 45

III. Noisy Refrigerator

1. *Cause:* Refrigerator not level.

Remedy: Adjust leveling screws or place thin piece of wood under the legs. Metal discs may be obtained from dealer.

2. *Cause:* Food containers may shake or rattle.

Remedy: Move containers so they do not touch each other or the cooling unit.

3. *Cause:* Loose parts.

Remedy: Tighten any loose bolts or screws.

4. *Cause:* Loose or worn belt.

Remedy: Tighten or replace. Fig. 46. If squeaking noise develops rub soap or belt dressing on the belt.

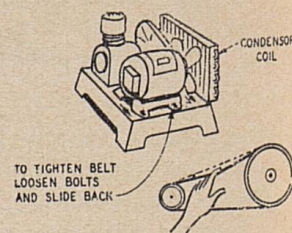

Fig. 46

IV. Motor Runs But Will Not Freeze Ice

1. *Cause:* Float valve stuck.

Remedy: Fill ice trays with hot water and place in the freezing compartment. Repeat if necessary.

V. Freezing Unit Collects Too Much Frost or Moisture Condensers in Cabinet

1. *Cause:* Door leaking air.

Remedy: Adjust door latch or replace rubber gasket, if worn. Fig. 43 or 44.

2. *Cause:* Uncovered foods in refrigerator.

Remedy: Cover all foods.

3. *Cause:* Incomplete defrosting.

Remedy: Defrost completely; see directions given under care and cleaning.

Refrigerators

4. *Cause:* Temperature too low in refrigerator.
Remedy: Set temperature control to obtain 35°F. to 45°F.

VI. Foods Will Not Keep

1. *Cause:* Improper storage or too high temperature.
Remedy: Remove vegetables from packages, discard wilted leaves and spoiled parts, wash thoroughly, drain and store in covered pan or hydrator in bottom of refrigerator. Unwrap meat, cover with waxed paper or butter paper, and place in the coldest part directly under freezing unit. Keep temperature between 35°F. to 45°F. Defrost when frost becomes 1/4-inch on freezing unit.

VII. Odor in Cabinet

1. *Cause:* Uncovered foods.
Remedy: See that all foods with a strong odor are covered.
2. *Cause:* Cabinet needs cleaning.
Remedy: Clean thoroughly according to directions found under care and cleaning.
3. *Cause:* Mechanical trouble.
Remedy: Call serviceman.

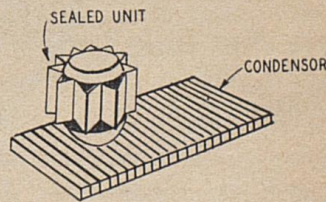

Fig. 47

Care, Cleaning and Operation

1. *Lubrication:* If your refrigerator is a belt-driven model similar to that shown in Fig. 46, oil it every two months with 6 to 10 drops of electric motor oil or motor oil of SAE No. 20 weight. Too much oil may damage the motor windings. Sealed units (with no oil cups) as shown in Fig. 47 require no oiling, as oil has been sealed in the unit at the factory.
2. Defrost whenever the frost on the freezing compartment exceeds 1/4-inch. Avoid prying trays or frost loose with a sharp instrument. Always melt the frost. This is done by turning control switch to defrosting, or turning off the electricity. The process may be speeded up by leaving the door open while defrosting, or by filling trays with hot water.
3. After defrosting, clean the entire cabinet interior, including freezing compartment, with a mild solution of warm water and baking soda. Do not use soap on the inside as it may cause an odor. Wipe up spilled foods immediately. Avoid the use of coarse cleaning powder on the inside or outside. If shelves become stained or rusted, clean with fine steel wool. A coating of unsalted fat will prevent rusting. If sliding shelves stick, wax sides with paraffin.

Refrigerators

4. Clean the outside of the cabinet with mild soap and warm water. The surface, if enameled, may be waxed two or three times a year for protection. Nicks and scratches should be painted with touch-up enamel to prevent rust.
5. Avoid touching the gasket when opening and shutting the door. Grease from hands softens rubber.
6. After setting control for fast freezing, and freezing is completed, be sure to turn control to normal setting.

ICE REFRIGERATORS

The same principles in regard to location, care, and cleaning of electric refrigerators apply to ice refrigerators. In addition, each week the drain pipe should be cleaned by pouring one cup of strong soda water through it. If possible take the drain and trap apart and scrub with soda to remove accumulation of slime. Rinse in boiling water. If there is a drip pan, it should be washed weekly. The ice rack should be washed with soda water and rinsed in boiling water, and cooled.

In order to keep the drainage system sweet and clean, a cup of cold baking soda solution - one tablespoon baking soda to a quart of water - should be poured over the ice about once a week. Since ice washes its own surface, there will be no baking soda taste in the next batch of ice cubes cut from the top of the ice block.

To get the best results in using the refrigerator never wrap the ice in paper. Do not crowd the shelves, or place food in the ice chamber. Place milk, butter, and meats directly under the ice, and foods with strong odors nearest the top.

KEROSENE REFRIGERATORS

The same principles in regard to location, care, and cleaning of electric refrigerators apply to kerosene refrigerators. There are a few additional precautions. Nothing should be built-in above a kerosene refrigerator. Be careful not to spill kerosene when filling tank.

In a kerosene refrigerator with a wick, carbon should be removed from the wick when the flame becomes unsteady and shows a yellow edge. For the wickless type, the carbon which has collected in the burner well and kerosene inlet should be removed at least once a month. While cleaning, drain and flush out the sediment bulb in the oil line between the tank and the float chamber. Clean the flame adjusting valve each week. The chimney, flues and other parts of the system need to be cleaned only occasionally.

RANGES

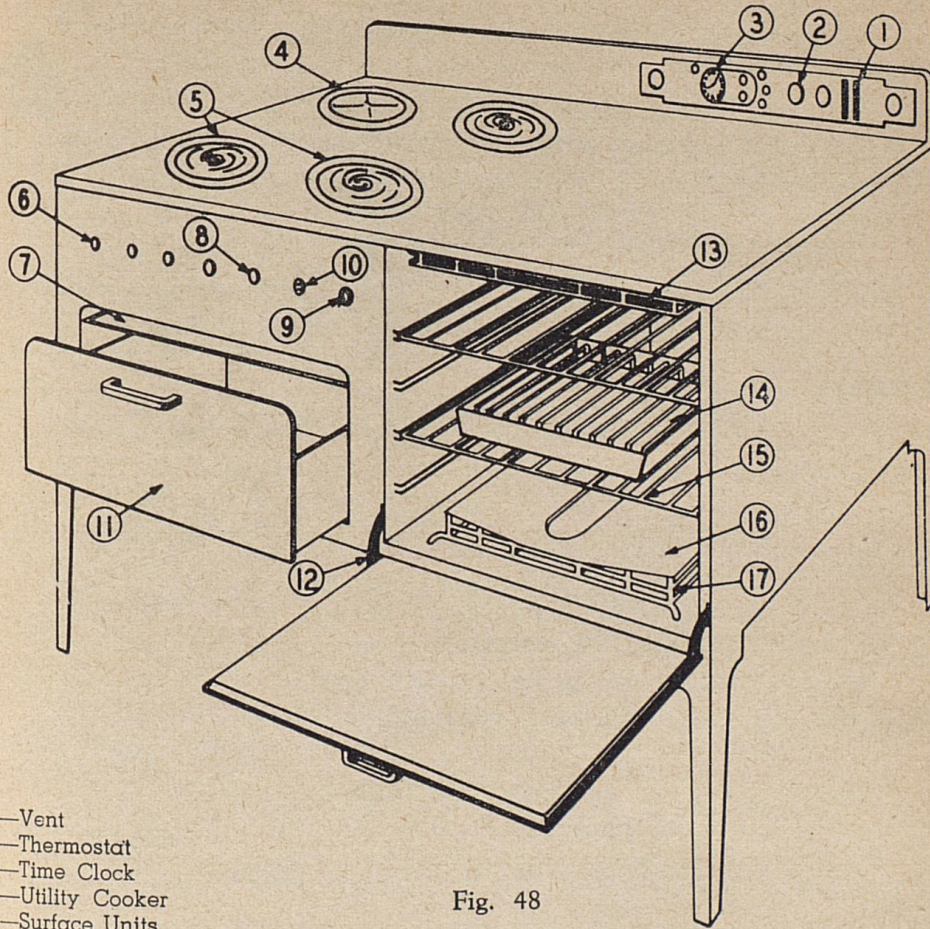

Fig. 48

- | | |
|---|--------------------------------|
| 1—Vent | 12—Counter Balancing Oven Door |
| 2—Thermostat | 13—Broiler Unit |
| 3—Time Clock | 14—Broiler Pan |
| 4—Utility Cooker | 15—Sliding Shelves |
| 5—Surface Units | 16—Baffle |
| 6—Unit Switches Panel | 17—Bottom Unit |
| 7—Drip Tray | |
| 8—Oven Switch | |
| 9—Pilot Light | |
| 10—Convenience Outlet | |
| 11—Utensil Storage Drawer or Warming Oven | |

ELECTRIC RANGE

1. Surface Unit Will Not Heat

1. Cause: (a) Range plug disconnected.
 (b) Range or main line fuse blown.
 (c) Power off temporarily.

Remedy: If all surface units are not heating, see if range plug is pushed firmly into receptable. Fig. 49. If this is not the cause, try lights in other parts of the house to see if fuse is blown or power is off. Replace range or main fuses if blown. Fig. 50.

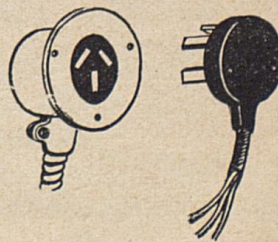

Fig. 49

Ranges

2. *Cause:* Loose connection or broken wire in unit.

Remedy: If wire is broken at terminals, clean end of wire and make proper connection. If the wire in open type unit is broken any place except at terminals, it can be repaired temporarily with a metal sleeve. Fig. 20 If unit is enclosed type, it must be sent to dealer for repair.

3. *Cause:* Switch defective.

Remedy: Call serviceman.

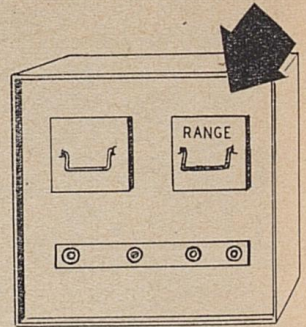

Fig. 50

II. Oven Will Not Heat

1. *Cause:* Same as for surface units (see I). Many times the terminals of the oven heating units are not pushed firmly into the receptacle.

Remedy: Same as for surface units. Push heating units firmly into receptacle. Fig. 51.

2. *Cause:* Timer set at "OFF" or "AUTOMATIC" position.

Remedy: See that timer is set at "Manual" position.

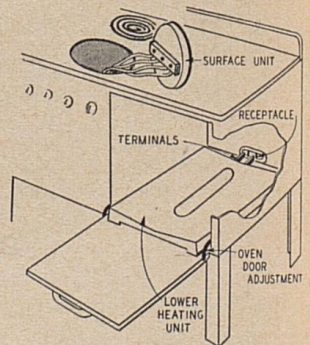

Fig. 51

III. Oven Heats Improperly

1. *Cause:* Thermostat set wrong or thermostat out of adjustment.

Remedy: Set thermostat for desired cooking temperature. If temperature is still incorrect, consult serviceman.

2. *Cause:* Oven door opened too often while baking.

Remedy: Watch the clock and do not open door until required cooking time is completed.

IV. Oven Browns Unevenly

1. *Cause:* Range not level.

Remedy: Test by placing a level or a large pan of water on oven rack. To level range, place wooden blocks under legs, or discs may be secured from dealer.

2. *Cause:* Oven door fits improperly.

Remedy: Check fit with a piece of paper. The door should fit tightly at the top but have $\frac{1}{8}$ -inch space at the bottom edge. The adjustment, Fig. 51, may require a serviceman.

Ranges

3. *Cause:* Utensils placed incorrectly in oven.
Remedy: Place pans in oven so that air can circulate around them. Stagger pans; do not place one pan directly over another.
4. *Cause:* Bent, warped, or unevenly discolored utensils.
Remedy: See kitchen utensils, page 32. A dark surface absorbs more heat than a bright one. For biscuits use a baking sheet. A pan with deep sides may be used upside down.
5. *Cause:* Oven door opened while baking.
Remedy: Do not open door until cooking time is completed.

V. Convenience Outlet on Range Will Not Operate

1. *Cause:* Fuse loose or blown.
Remedy: A plug type fuse is located in the range. It may be found at the back, in the front, or under a surface unit. It may be necessary to remove the drawer to find fuse.

Care, Cleaning and Operation

1. Clean heating elements by burning off any spilled food and brushing with a soft brush. Never scrape it off or use water to clean unit.
2. Keep the 4 S's away from the wires of an open unit - salt, soda, soap, and sugar.
3. Avoid using a higher heat than necessary.
4. Rotate the use of the surface units as you do your spare tire on your car, using the largest unit only when using a large pan. If the switch turns in both directions, rotate the direction you turn it.
5. Keep the drip pans beneath the surface units clean to prevent burning of wires leading to surface units. In order to clean, it may be necessary to lift up the surface unit, Fig. 51.
6. Use utensils with flat bottoms and tight fitting lids. When a large utensil must be used, protect the porcelain enamel around the surface with a heavy asbestos sheet larger than the utensil with a hole in the center the size of the unit.
7. Clean the porcelain top after it is cool with warm, soapy water, or whiting. Wipe up lemon, vinegar, or other acids immediately with a dry cloth if range is hot. Do not drag heavy utensils across the top of range.
8. Clean oven with soap and water. Prevent rust by rubbing with unsalted fat. Leave door open until oven is cool. Never store food in oven. Avoid putting heavy objects on oven door.
9. Be sure the deep well cooker has water in it before you turn on the switch. Always remove the pan and use a rack when baking in a deep well cooker.
10. Keep broiler pan clean and stored in utensil drawer except when broiling.

Ranges

COAL OR WOOD RANGE

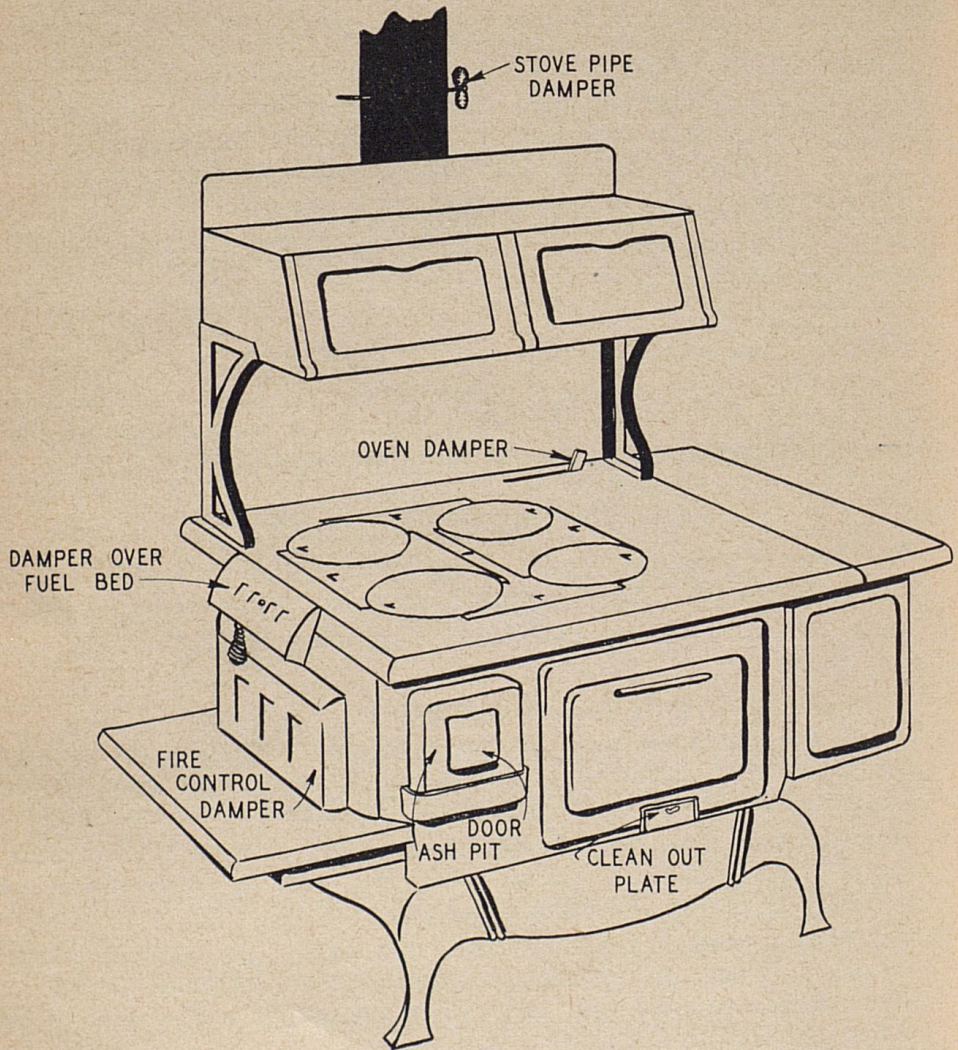

Fig. 52

1. **Trouble:** Stove heats slowly.

Remedy:

- When building fire, fill fire box about half full of fuel and attend the fire regularly.
- Avoid using green or wet wood.
- Close the stove pipe damper and open the fire control damper for quick heating, Fig. 52.
- Clean out all soot from under lids, range top, and around oven, and at clean out plate, Fig. 52.

2. **Trouble:** Stove smokes.

Remedy:

- See that chimney is proper height above roof, correct

Ranges

size, and stove pipe connections are tight.

- b. Clean pipe, flue, and chimney of soot. Tap the pipe gently to loosen soot deposit. About once a year disconnect the pipe, carry it out doors, and clean the inside with an old broom, brush, or cloth tied to the end of a stick. Clean the chimney flue once a year by lowering and raising an old sack partly filled with straw.

3. **Trouble:** Oven browns unevenly.

- Remedy:**
- a. Attend the fire regularly instead of putting on too much coal or wood at one time.
 - b. Clean out the soot around the oven.
 - c. Use correctly dampers and draft-checking devices, Fig. 52. Do not allow the range to become red hot as this warps the stove.

Most good stoves have several drafts and dampers. These are as follows:

The fire control damper below the firebox, Fig. 52, admits the necessary air for combustion. Keep the ash pit door, Fig. 52, closed.

The damper over the fuel bed, Fig. 52, admits cold air on top of the fire. Open it slightly when adding fresh fuel to aid in combustion of gases.

The oven damper, Fig. 52, reduces the draft from the chimney and draws the heat around the oven.

The stove pipe damper, Fig. 52, is used to regulate the chimney draft. When a strong wind is blowing, keep this damper partly closed, except when starting a fire. On wet days, leave this damper entirely open.

Care, Cleaning and Operation

1. Remove all ashes regularly from the firebox and ash pan, Fig. 52. Never allow ashes in the ash pit to remain in contact with the grates.
2. Clean soot from chimney, flue and pipe once a year, and from bottom of lids and around oven once a week.
3. Wash the inside of the oven and racks with soap and water, rinse, and dry thoroughly. If inside is rusted, clean with steel wool and paint with aluminum paint. Never store food in the oven. Allow oven door to remain slightly open until entirely cool.
4. Keep the top of the stove in good condition by rubbing it each day while it is still warm with a piece of waxed paper or unsalted fat, rather than blacking. Clean the nickel, chromium, or enamel parts with soap and whiting.
5. If stove has a water back connected with hot water tank, be careful that it does not freeze in cold weather. In severe weather cover a bed of coals with ashes or drain the tank.

Ranges

KEROSENE RANGE

Care, Cleaning and Operation

1. Be sure range is level and not located in a draft.
3. See that parts of burner and chimney fit together properly.
3. Use a small brush or paper napkin to clean wicks, Fig 54. Do not cut with scissors. If wick has a beveled edge, this should be carefully maintained. If wicks become very dirty, remove and boil in a solution of washing soda (sal soda). Rinse and dry thoroughly. In replacing a wick, adjust it level with the top of the outside of the wick tube.

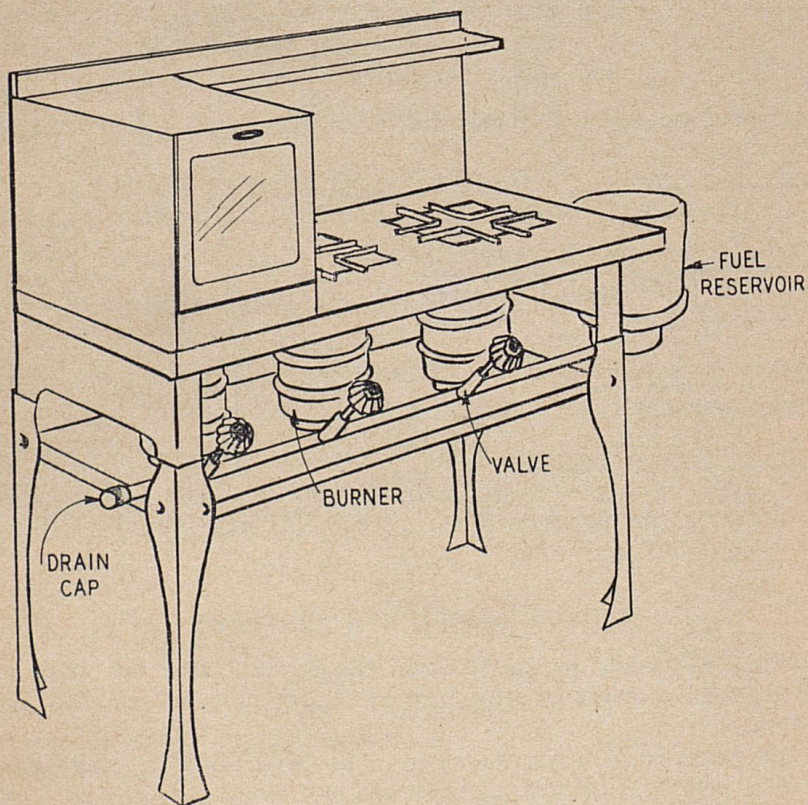

Fig. 53

4. Wipe the outside of the stove daily after it cools with a damp cloth, and dry thoroughly.
5. Keep spilled food wiped up in the oven and leave door open until it cools.
6. Clean isinglass in chimneys or oven door with vinegar.
7. Once a year, or oftener if necessary, clean range thoroughly:

Burners and Chimneys: (Fig. 54). Boil perforated sections in soda

Ranges

solution, wash, and polish with a hot mixture of vinegar and salt (4 parts vinegar to 2 parts salt.) Wash and dry thoroughly. Wash chimneys with warm, soapy water, rinse and dry thoroughly. Remove rust spots with fine steel wool.

Feed pipe: Drain the feed pipe, preferably every three months, by loosening the drain cap, Fig. 53, and tilting the stove. Clean the pipe with a rag tied securely to a long wire. Flush with kerosene.

Oil Tank: Drain, fill with washing soda solution, let stand 20 minutes, wash with warm soapy water, rinse and thoroughly dry before refilling with kerosene.

8. Adjust flame height slowly to a blue flame that has small yellow tips.
9. To avoid odor and smoke, raise chimney on short drum burners after turning control device to "off" position.
10. To store range: remove wicks; clean wick tubes and feed line; drain kerosene; rub all parts likely to rust with unsalted fat and place in a clean, dry place. Wrap chimneys and grids in moisture resistant paper.

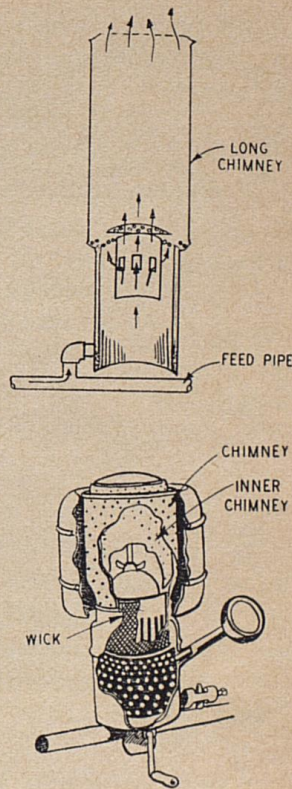

Fig. 54

WASHING MACHINES

1. Motor Will Not Operate

1. **Cause:** Fuse blown, loose connection at wall outlet, or cord or plug needs repair.

Remedy: See page 4, Fuses - Cords - Plugs. To prevent blowing a fuse, never start motor while cold; never start motor when agitator is at "ON" position; never start motor and agitator with machine loaded; never overload machine.

2. **Cause:** Motor troubles.

Remedy: See motor troubles, Page 13.

3. **Cause:** Machine cold; oil stiff.

Remedy: Move into a warm room one to two hours before using, or fill tub with warm water.

Washing Machines

II. Wringer Does Not Operate Properly (Wringer Type, Fig. 55).

1. **Cause:** Wringer lever not turned completely to "ON" position. Fig. 55.

Remedy: Move lever to "ON" position.

2. **Cause:** Improper pressure on wringer roll.

Remedy: Adjust for correct pressure or tension. Fig. 55. There are other wringer troubles of a mechanical nature that cannot be repaired in the home. The wringer can be easily lifted from the machine and taken for repair to a serviceman, dealer, or manufacturer.

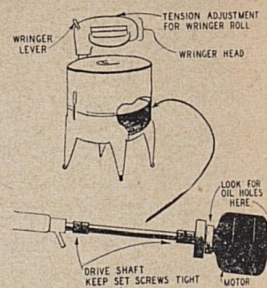

Fig. 55

III. Agitator Does Not Operate Properly—

1. **Cause:** Agitator not in place. On some models, cap screw at top of agitator may be loose.

Remedy: Keep cap screw on top of agitator tight. Keep agitator pushed down in place. See that dirt has not collected underneath the agitator.

2. **Cause:** Agitator lever not turned completely to "ON" position.

Remedy: Move lever to "ON" position.

3. **Cause:** Drive coupling loose.

Remedy: Tighten set screws on drive coupling at motor end and agitator shaft end. Fig. 55.

IV. Noisy Washing Machines—

1. **Cause:** Parts loose or worn.

Remedy: Tighten all bolts and screws. Keep all parts repaired.

2. **Cause:** Machine not level.

Remedy: Place thin wood under legs.

3. **Cause:** Spinner vibrating because it is unevenly loaded.

Remedy: Pack clothes down evenly in spinner as it is filled.

Care, Cleaning and Operation

1. **Lubrication:** With most electrically driven washers, lubrication has been provided at the factory for the life of the washer. However, examine the wringer head and motor (Fig. 55) for oil holes. Oil motor monthly, with 2 or 3 drops of electric motor oil. Oil casters frequently.
2. For safety with an electric washer, stand on a dry floor and be sure

Washing Machines

hands are dry when you connect the plug in order to prevent shock. Always check safety pressure release on wringer before using.

3. Be sure the water level is even with the mark indicated on the inside of the washer or on the agitator. If it is allowed to get too high, water may drain into the gear case where it will do serious damage. If it is too low, a rubbing, scraping sound may be heard.
4. Avoid overloading the machine as it will strain the mechanism of the washer and overheat the motor as well as fail to get the clothes clean. The clothes should circulate freely in the water.
5. Wash by the clock. If clothes are washed too long, dirt from the water goes back into the clothes, electricity is wasted, and the machine gets unnecessary wear. Allow 5 to 10 minutes for slightly soiled cotton and linen, 10 to 15 minutes for very soiled cotton, and 2 to 4 minutes for wool, silk, and synthetics.
6. Release the pressure on the wringer rolls immediately after each use.
7. Pumps: If the washer contains a pump, remove the cover from the drain and clean out the pump, if it becomes clogged. Always drain all the water from the hose after each use.
8. After each washing, remove the agitator and clean the underside and the post thoroughly. Use care in handling the agitator to avoid nicks and scratches which will cause undue wear on clothing and eventually necessitate a new agitator. Clean the inside and outside of the tub with hot, soapy water, rinse and dry. Rub stubborn spots with whiting. Remove hard water deposits with vinegar and water. To remove stains on a galvanized tub, apply a paste of kerosene and baking soda, rinse, and dry. To remove the green stain on a copper tub, rub with hot vinegar and salt, rinse, and dry. If enameled, wax the outside to protect the finish. Rub the metal frame with unsalted fat to prevent rusting.
9. Wash the rollers on wringer in warm, soapy water; rinse, and dry. If necessary to use kerosene to remove stains, wash off with soapy water.
10. Store in a dry place, away from sun and heat. Leave lid slightly open. Leave drain valve open. Cover against dirt and dampness. You can make or buy a dustproof cover that slips over the entire machine.
11. Disconnect cord, wipe dry beginning at the motor end, and wind loosely over the hook on the side of the washer. Never leave cord lying on the floor.

GASOLINE WASHING MACHINES

The care and cleaning of gasoline machines is the same as electric machines.

KITCHEN UTENSILS

1. *Trouble:* Dents in utensil.

Remedy: Place utensil on a solid surface and tap out dent with a wooden mallet. If a metal hammer is used cover the hammer head with cloth or place a small block of wood next to the pan.

2. *Trouble:* Warped skillet.

Remedy: Heat slowly for 10 minutes, turn upside down and place a piece of wood over the entire bottom. Hammer on the wood until the skillet is flat. If the bulge is toward the inside of the skillet, hammer on the inside. To prevent warping, do not pour cold water on a hot skillet.

3. *Trouble:* Holes in utensil.

Remedy: Repair with aluminum patch that can usually be purchased at hardware or dime stores. Fig. 56. Some utensils can be soldered.

4. *Trouble:* Lid with a broken knob

Remedy: Replace with a new knob that can be purchased at hardware or dime stores.

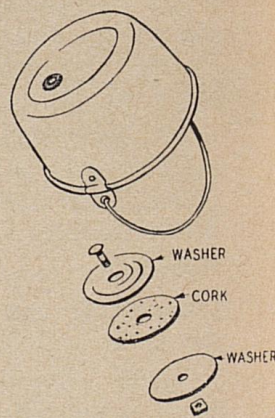

Fig. 56

Care and Cleaning

An excellent cleaner for home use, that is cheaper than most fine scouring powder, can be made by shaving scraps of soap into fine flakes and dissolving in boiling water and adding enough Spanish whiting to make a paste. Spanish whiting is an inexpensive fine chalk which cleans without scratching or injuring the surface. It can usually be purchased at hardware or paint stores. Whiting can also be used dry as a powder for cleaning.

1. If food has burned in an *enamel*, *agate*, or *iron* pan, boil soda water in it and clean with fine steel wool and whiting. Do not use soda, strongly alkaline soap, or cleaning powder on *aluminum*. Use vinegar, fine steel wool and whiting. Never scrape aluminum, enamel or agate ware with metal object; use wooden spoon or wooden clothes pin.
2. Avoid leaving food standing in an *aluminum* vessel longer than necessary. Minerals in food cause pitting of aluminum.
3. To brighten a stained and discolored *aluminum* pan, boil an acid, such as vinegar, in it and rub with fine steel wool and whiting. Cer-

Kitchen Utensils

tain foods such as sour milk, tomatoes, rhubarb, tart apples, or plums cooked in aluminum will brighten it. These foods will be safe for eating. Clean discolored *brass* or *copper* by rubbing it with hot buttermilk or hot vinegar and salt, and washing thoroughly. Remove stains on *enamel* pans with a bleaching agent, such as borax.

4. Dry thoroughly *iron* and *tin* utensils and store uncovered in a dry place to prevent rusting. If it must be stored for some time, give it a protective coat of unsalted fat. Do not scour tin pans. This will remove the tin coating and cause rusting.
5. Do not subject *enamel*, *agate ware*, or *glass* to sudden changes of temperature, to blows, or to scraping with sharp objects. Do not place hot glass on a cold surface or touch it with a wet cloth.
6. Clean *chromium* and *nickel*, which are soft metals, with soap and water. For stubborn stains, use whiting. Never use coarse scouring powder.
7. Clean *galvanized* buckets and garbage pails with coarse scouring powder. Scald garbage pails and air in the sunshine to prevent odors.
8. To prevent dents in utensils, store them in an easy-to-reach place so they can be removed without moving others. Make racks for storing pots, lids, pie pans, thin baking sheets, and trays.

KNIVES

1. Sharpen knives often. A tapered steel rod, oil stone, or grindstone can be used. See that the cutting edge always leads when sharpening. Fig. 57.
2. To keep knives sharp, cut food on wooden cutting board and not on a metallic or enameled surface. Avoid leaving knives in hot water. Store in a wooden wall rack, or a holder may be made by tacking a leather strip to the wall. Never store knives loose in a drawer as the edges become dulled.

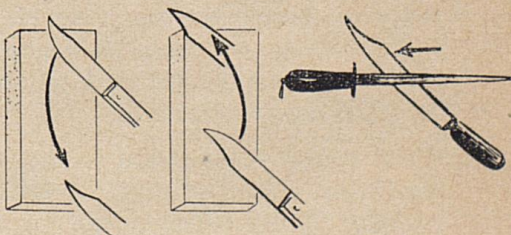

Fig. 57

PRESSURE COOKER

1. After each use, clean pressure cooker, Fig. 58, like any aluminum utensil, page 32. Wipe inside of lid with a damp cloth. Handle lid carefully and never put in water. Leave lid off the cooker when not in use, as storing it closed causes the aluminum to pit and discolor.
2. Take the safety valve apart and clean the parts often, Fig. 59. Keep the ball clean with fine steel wool or vinegar. **Caution:** Unless this is done you have no safety protection. Safety valve should "pop off" between 16 and 20 pounds pressure; if it "pops off" too soon, stretch spring, Fig. 59; if it does not "pop off" mash spring down some. A new spring may be needed. Clean pet cock, Fig. 58, with fine steel wool.

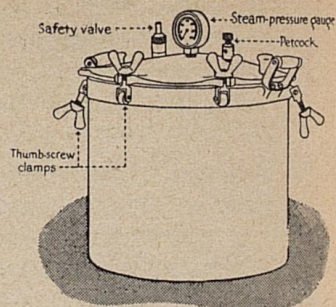

Fig. 58

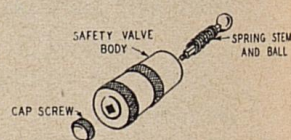

Fig. 59

3. **Caution:** Never open cooker without looking at the gauge to see that it registers "zero", and at the pet cock to see that it is open and all steam has escaped, Fig. 58. Cool gradually and always open lid away from you.
4. Keep the right amount of water in cooker.
5. Always keep opening to gauge clean.
6. Have pressure gauge, Fig. 58, tested whenever possible. If it fails to return to "zero", it may be adjusted by the manufacturer or a new gauge may be bought.
7. If lid has a tendency to stick, rub edges of lid and cooker with unsalted fat before sealing. Never pry lid loose with a metal object as it will damage the seal. A strong piece of wood may be used. Sometimes removing the pet cock will allow entrance of air and the lid can be more easily removed.
8. If the cooker leaks steam so that the gauge will not register, send the lid to the manufacturer. If only a small amount leaks around the lid, smooth the edges of the lid and cooker with emery cloth or fine steel wool. If the lid has a rubber gasket which has become worn, replace it. If it leaks at the pet cock, order a new pet cock from the manufacturer.

SIMPLE PLUMBING

Types of Faucets

1. Compression. Fig. 60.
2. Fuller. Fig. 61.
3. Ground Key. Fig. 62.

Repair of Compression Faucets Fig. 60

1. Shut off water to faucet.
2. Unscrew cap nut. Fig. 60.
3. Unscrew valve stem. Fig. 60.
4. Remove washer screw. Fig. 60.
5. Replace washer. Fig. 60.
6. Reassemble.
7. If faucet still leaks, ream out the valve seat, which is probably rough.

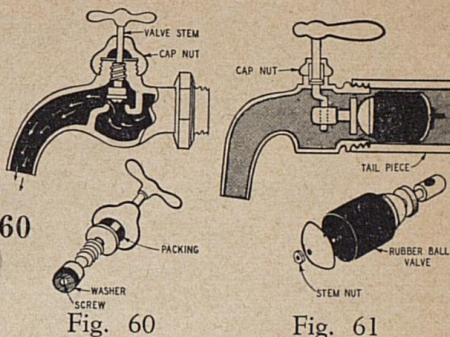

Fig. 60

Fig. 61

Cutting a new valve seat

- a. Shut off water to faucet.
- b. Unscrew cap nut and valve stem.
- c. Insert cutting tool in faucet. Fig. 63.
- d. Screw threaded cone into body of faucet. Fig. 63.
- e. Rotate cutting tool in clockwise direction until valve seat is smooth. Fig. 63.

Caution: Very little pressure is needed on the cutting tool. The valve seat is brass and cuts easily.

- f. Remove all cuttings and reassemble.

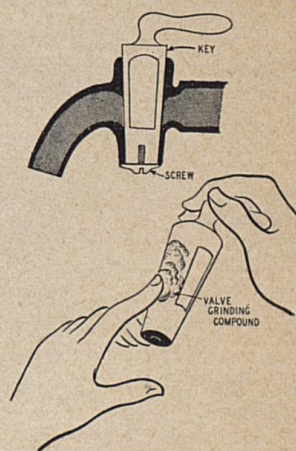

Fig. 62

Repair of Fuller Type Faucet Fig. 61

1. Shut off water to faucet.
2. Unscrew the faucet from tail piece. Fig. 61.
3. Unscrew stem nut.
4. Replace with new rubber ball valve and reassemble.

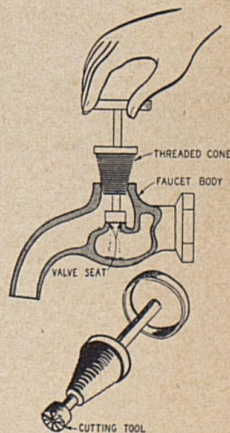

Fig. 63

Repair of Ground Key Faucet Fig. 62

1. Shut off water to faucet.
2. Remove large screw at bottom of faucet. Fig. 62.
3. Remove key from faucet body and place valve grinding compound over surface. Fig. 62. Insert key back in faucet body and turn back and forth until smooth surface is obtained.
4. Clean key thoroughly and reassemble.

Simple Plumbing

IMPORTANT: Keep extra set of faucet washers on hand.

Water Closet Fixtures

I. Water runs out of overflow pipe

1. **Cause:** Leaky or water-logged float ball.

Remedy: Remove all water from copper float ball and solder leak or replace with new float ball.

2. **Cause:** Float ball rod bent.

Remedy: Bend float ball rod downward.

3. **Cause:** Faulty inlet valve.

Remedy:

- Shut off water to closet.
- Remove float ball and rod.
- Remove thumb screws and lever.
- Lift out plunger.
- Replace soft rubber washer and reassemble.

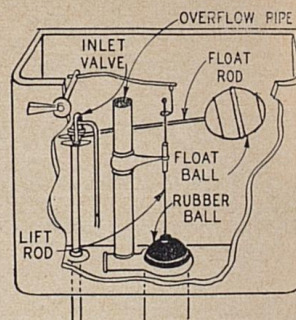

Fig. 64

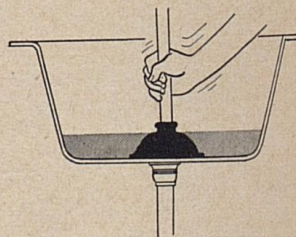

Fig. 65

II. Water Runs Through Closet

1. **Cause:** Improper seating of rubber ball. Fig. 64.

Remedy:

- Be sure lift rod or wire is straight and works freely.
- Replace rubber ball if worn. Fig. 64.

IMPORTANT Keep extra set of water closet washers and valves on hand.

Cleaning Drains

- Fig. 65 shows a suction plunger used to clean sluggish drains.
- A can of household commercial chemical can be used in drains occasionally to help keep them clean.
- Water traps in kitchen sinks and wash bowls can be cleaned as shown in Fig. 66.

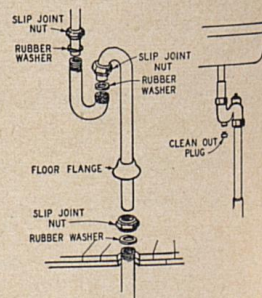

Fig. 66

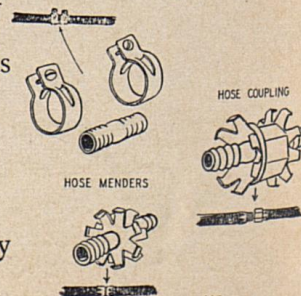

Fig. 67

Hose Menders or Connectors

A break in garden hose can be repaired by one of the methods as shown in Fig. 67.