

# UNIVERSITY OF KENTUCKY

COLLEGE OF AGRICULTURE

Extension Division

THOMAS P. COOPER, Dean and Director

CIRCULAR NO. 124

WOOD-WORKING MERIT COURSE

Junior Agricultural Clubs

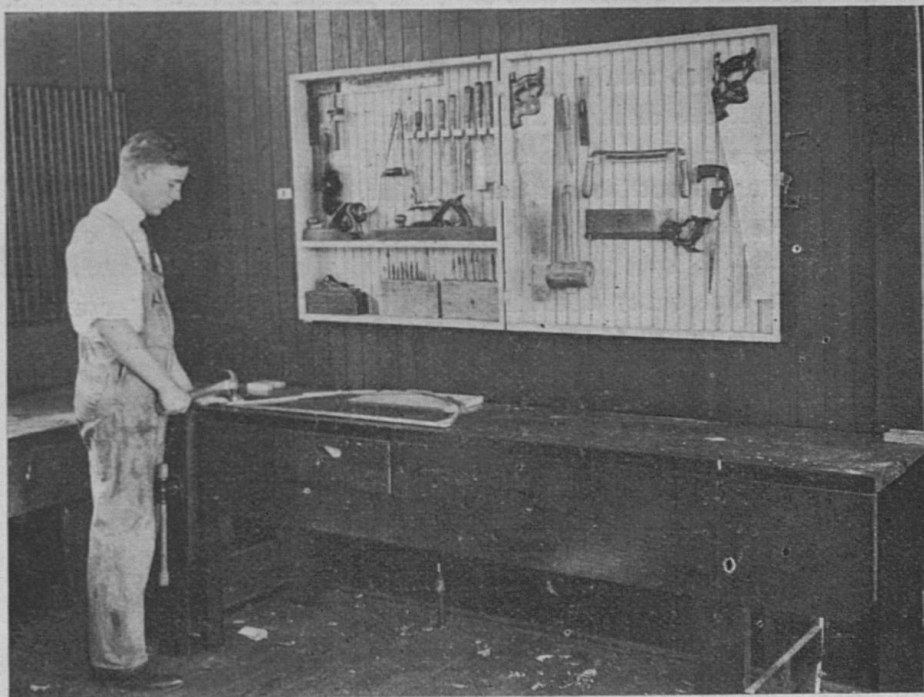

By

J. B. KELLEY and EARL G. WELCH

Lexington, Kentucky

MARCH, 1922

Published in connection with the agricultural extension work carried on by cooperation of the College of Agriculture, University of Kentucky, with the United States Department of Agriculture, and distributed in furtherance of the work provided for in the Act of Congress of May 8, 1914.

## REQUIREMENTS

1. Club members must be 10 to 18 years of age (inclusive).
2. Enroll not later than May 1 for summer work, and December 1 for winter work.
3. The club member must agree to do the following things:
  - a. Make ten articles shown in this circular.
  - b. Follow the directions in this circular.
  - c. Co-operate in every way with his county agent and other club members.
  - d. Attend club meetings.
  - e. Exhibit one or more articles at some club show or other fair.
  - f. Keep a record of the total cost of making three articles, according to outlines in this circular.
  - g. Write a short story of the project according to outline furnished.
  - h. Give the county agent not later than six months after enrollment, a report of work accomplished, with story and expense records of three articles.
4. In awarding prizes, club members will be graded upon the following basis:

Neatness .....	25 points
Accuracy .....	60 points
Report .....	15 points

## ENROLLMENT

Each member must apply for the wood-working course to the county agent or State Club Leader. The consent of the parents or guardian should be obtained before this is done. The club member must enroll in some farm or home project while working on this merit course.

## CIRCULAR NO. 124

---

### WOOD-WORKING MERIT COURSE.

#### Junior Agricultural Clubs

---

The object of the wood-working course is to furnish the members of the Junior Agricultural clubs with definite plans for making simple and useful articles. Exercises have been selected which may be made with the limited amount of materials, tools and equipment commonly found on the farm. In making these exercises, the knowledge obtained in the use and care of tools will assist in giving club members self confidence and ability to plan and execute the more difficult problems of repair and construction.

#### SUGGESTIONS FOR CLUB MEMBERS

Each club member should derive a great deal of pleasure in making the various articles, as most people like to do constructive work. Carefulness, neatness, accuracy, economy of time, the development of mechanical skill and clear thinking are some of the things you should strive to develop in yourself in doing the work.

Careful study of the drawings, bills of materials and instructions before starting an exercise will lessen the number of mistakes. For each lesson mechanical drawings are furnished showing the details of construction. Another drawing shows the parts assembled into the finished article.

The bill of materials gives the number and sizes of the pieces needed. When material cannot be purchased in the desired lengths and must be cut from stock lumber, care should be taken to lay out the work so as not to waste material.

The real value you will get out of the work will depend upon your ability to learn to make useful articles for your home.

#### FARM SHOP

A good shop on the farm is usually a profitable investment; a place where all kinds of repair work can be done quickly, especially during the rush season. It will often save a half day's time that would otherwise be taken to have the work done in town.

It is not necessary for the Junior Club members to have such a shop in order to do the work outlined in this project. Any well lighted and ventilated room having sufficient floor space for the work-bench and space for doing the work may be used. It will be convenient if wall space over the work-bench can be provided on which to hang the tools. They can be arranged on the wall or placed in a wall case. Space for the shop may be found in the basement of the house or in a corner in the machine shed, barn or some other outbuilding.

#### CARE AND REPAIR OF TOOLS

In this circular is given a list of wood-working tools which it is desirable to have on every farm. It is not, however, necessary to purchase all these tools in order to make the articles shown in this project. You may already have some of these tools on your farm, and the others you can purchase as you see fit. It pays to buy tools of good quality because they last longer and are easier to keep in good condition.

In order to do good work, the tools must be kept in the best condition. It is easier to do accurate work with clean sharp tools than with rusty, dull ones.

Edge tools should be ground on a grindstone at an angle of about 25 degrees, depending upon the temper of the tool and kind of wood to be cut, whether hard or soft, soft wood allowing the use of a sharper angle. Finish sharpening the tool by whetting it on an oilstone, holding it at an angle slightly greater than the angle used on the grindstone.

You should have a definite place in which to keep each tool and should keep it in its place when not in use. All the metal parts should be oiled to prevent rusting.

It is advisable for the club members to have an experienced person teach them how to sharpen the saws and various tools.

#### FARM WOODWORKING TOOLS

- 1—16-inch compass saw.
- 1—26-inch rip-saw, 5-point.
- 1—Coping saw with metal handle.
- 1—24-in. cross-cut saw, 10 point.
- 1—15-in. 2¼" jack plane.
- 1—saw set.
- 1—saw vice.
- 1—6-in. block plane.
- 1—8-in. draw knife.
- 4—Socket firmer chisels, ¼", ½", 1", 1½".
- 1—1-lb. round nose claw hammer.
- 1—mallet, mortised handle.
- 1—hand axe.
- 1—framing square.
- 1—sliding T bevel.
- 1—6" try square.
- 1—8-in. dividers.
- 1—2 ft. brass bound box rule.
- 1—marking gage.
- 1—10-in. ratchet brace.
- 5—bits, ¼", ⅜", ½", ⅝", ¾".
- 1—expansion bit, ⅞" to 3".
- 4—twist drills, ¼", ⅝/16", ⅜", ½".
- 1—countersink.
- 2—gimlets No. 5 and No. 7.
- 1—oilstone 1" x 2" x 7".
- 2—wood rasps, 10-in. half round.
- 2—screw drivers, 1 small and 1 large.
- 1—nail set.
- 1—6-in. pliers.
- 1—10-in. flat file.
- 1—8-in. tringular file.
- 1—6 in. slim tapered triangular file.

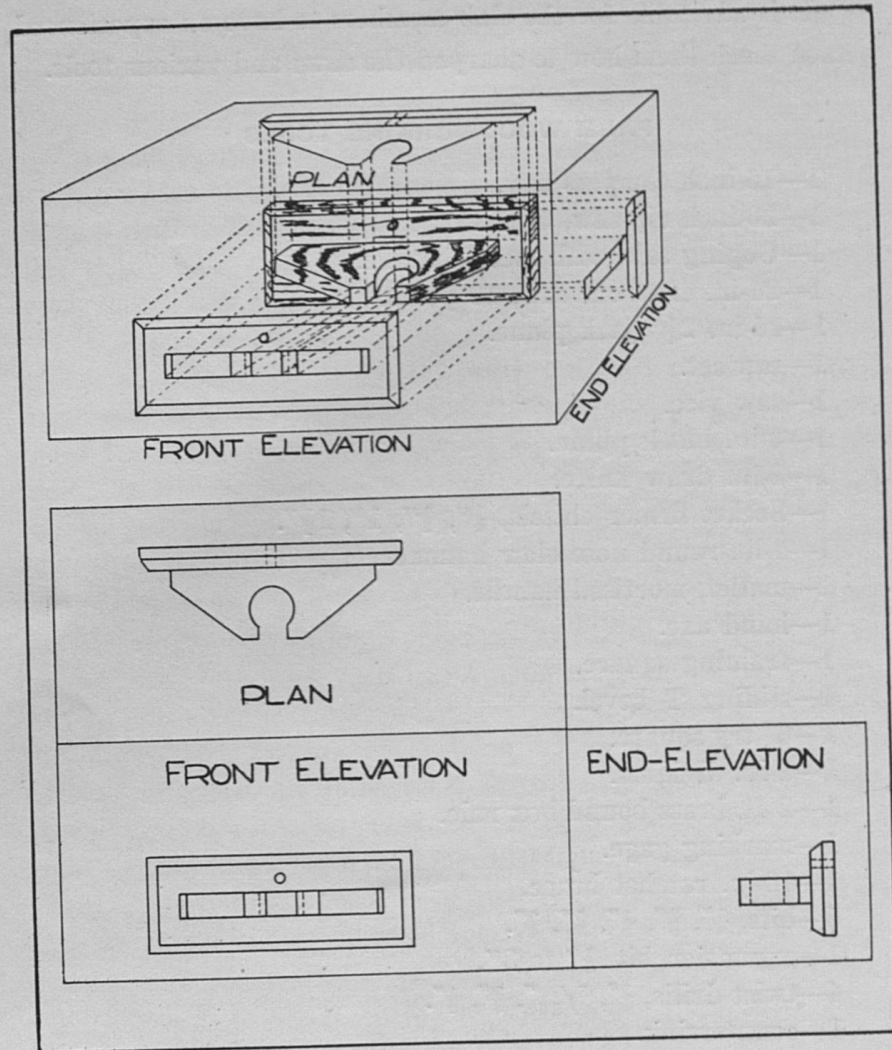

#### EXPLANATION OF DRAWINGS

The various articles presented in this circular are illustrated by means of projection drawings (shop drawings) and also by a drawing showing the object as it will appear when all assembled.

As it is rather difficult for a beginner to understand shop drawings, the following explanation will prove helpful.

In making shop drawings (projection drawings) we use three views; the plan, which represents the appearance of the

object as viewed from above; the front elevation, its appearance as viewed from straight in front; and the end elevation as seen from the right end.

A careful study of drawings of a broom holder on page 6 will assist you in learning how to interpret the plans for the various articles given in this circular. On the upper part of the page is a perspective drawing of the broom holder represented as placed inside a glass box. If a person looking down thru the top of the glass box should draw on the glass the outline of the object as it appears, he would have the lines shown in the plan view; looking thru the glass at the front, the object would appear the same as shown by the front elevation, and looking thru the side it would appear to you as shown by the drawing of the end elevation.

If after drawing these three views on the glass box, you could flatten out the box, the top, front and end elevations would appear to you as shown by the drawings at the bottom of the page. These three views, properly dimensioned, are sometimes called working or shop drawings. The solid lines represent lines on the object which we can see and the dotted lines represent hidden lines. After a little practice you should be able to get a mental picture of the assembled object by looking at these views.

#### FARM SHOP WORK-BENCH

##### Hardware for Bench:

8 carriage bolts  $\frac{3}{8}$ " x  $6\frac{1}{2}$ " with washers for holding sills to legs.

4 carriage bolts  $\frac{3}{8}$ " x 7" with washers for holding top to sills.

30 flat-head bright wood screws,  $1\frac{3}{4}$ " No. 8 or 9 for fastening top boards, apron, braces and drawer guides.

1 doz. 4d common nails for assembling drawer guides.

$\frac{1}{4}$  lb. 6d finishing nails for drawer.

##### Hardware for Vise:

1 iron bench screw  $\frac{1}{2}$ " or 1" with handle.

4 flat-head bright wood screws  $1\frac{1}{2}$ " No. 12 for fastening bench screw to jaw.

1 carriage bolt  $\frac{3}{8}$ " x 6" with washer to fasten lower jaw brace to jaw.

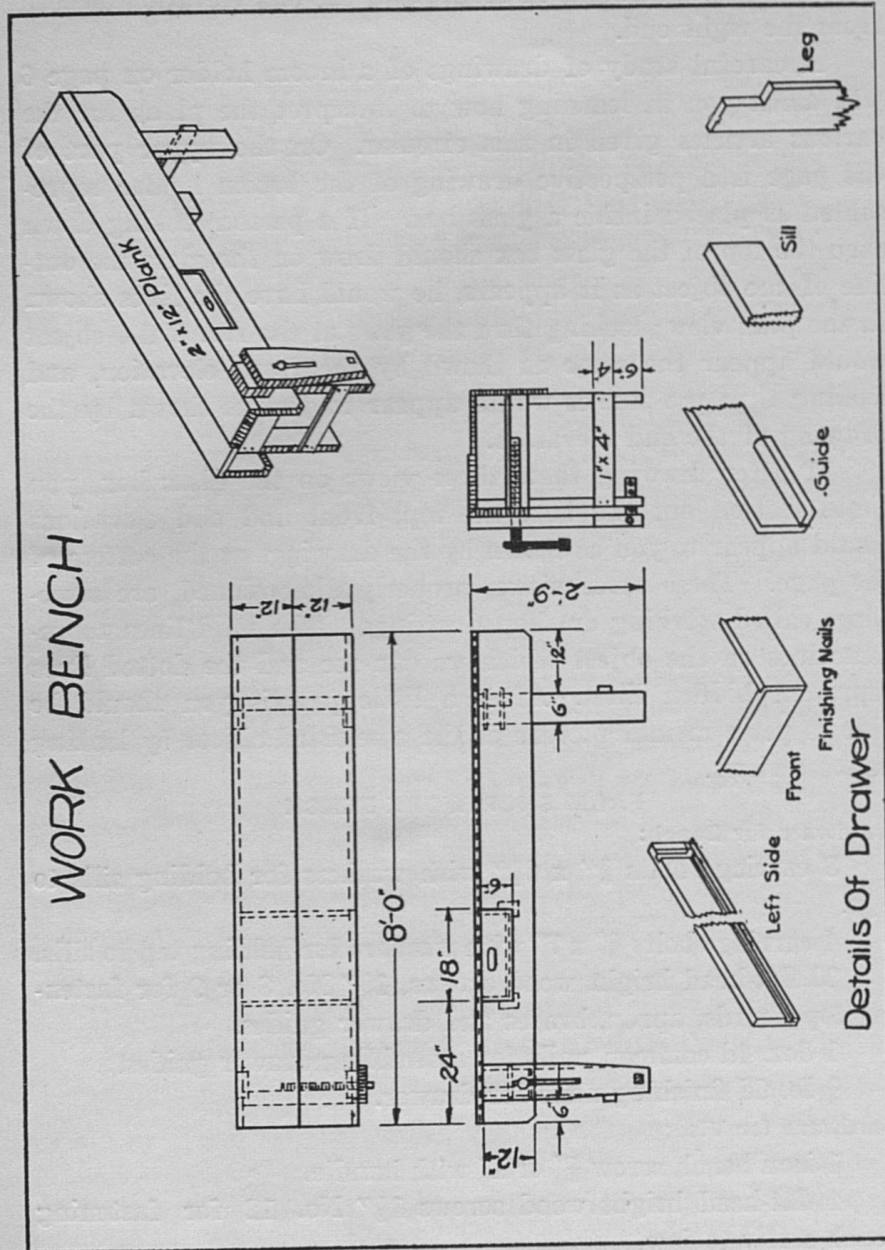

Benc  
Side  
Legs  
Cross  
End  
Draw  
Draw  
Draw  
Draw  
Lun  
Jaw  
Jaw

wo  
par  
fac



Bill of Materials

Use	No. of Pieces	Size
Bench top	1 (hard pine or oak)	2" x 12" x 8'
	1 (soft wood)	1" x 12" x 8'
Sides or aprons	2 (soft wood)	1" x 12" x 8"
Legs	4 (soft or hard wood)	2" x 6" x 2' 7"
Cross sills	2	2" x 4" x 22 $\frac{3}{8}$ "
End braces	2	1" x 4" x 22 $\frac{3}{8}$ "
Drawer guides	2	1" x 3" x 22 $\frac{3}{8}$ "
Drawer guides	2	1" x 1" x 22 $\frac{3}{8}$ "
Drawer front	1	1" x 6" x 18"
Drawer sides	2	1" x 6" x 20"
Drawer back	1	1" x 5" x 17"
Drawer bottom	2	1" x 9 $\frac{3}{4}$ " x 17"
Lumber for vise		
Jaw	1 oak	2" x 6" x 2' 6"
Jaw brace	1 (oak or maple)	1" x 2" x 16"

DIRECTIONS

Well seasoned lumber should be used for all parts of the work-bench and vise. Soft or hard wood may be used for all parts except the vise and top plank. All lumber should be surfaced on at least one side and two edges.

1. Cut the legs to length 2' 7" and lay out the mortises at one end of each to receive the cross sills, removing stock with cross-cut and rip-saws.
2. Cut the sills to length 22 $\frac{3}{8}$ " and fasten them to the legs with  $\frac{3}{8}$ " x 6 $\frac{1}{2}$ " carriage bolts. Use carpenter square to assure right angles between the legs and sills.
3. Screw on the cross braces at bottom of legs with two 1 $\frac{3}{4}$ " x No. 8 or 9 flat-head screws.
4. Cut the drawer opening in the upper end of front apron 18" long, and 6" deep, two feet from the front end of bench. By carefully sawing this board out with cross-cut saw, it may be used for drawer head.

5. Fasten the aprons to the legs, using three  $1\frac{3}{4}$ " No. 8 or 9 flat-head screws at each leg. Place screws on vise leg so they will not interfere with vise screw.
6. Locate and bore the hole for the vise screw with a bit  $\frac{1}{16}$ " larger than the bench screw, thru the apron and leg on a center line of the leg 8" from top of bench.
7. Mortise out the rectangular opening for vise brace 1" x 2" on a center line of jaw 3" from bottom. Fasten brace in place with a  $\frac{3}{8}$ " x 6" carriage bolt.
8. Assemble the vise screw and jaw, fastening the screw washer and threaded collar in place with  $1\frac{3}{4}$ " No. 12 flat-head screws.
9. Make the drawer and guides according to detail drawings. The method of constructing drawer depends upon the tools available for the work. The grooving can be done with a saw, chisel, and mallet. If tools are not available for grooving, make the drawer like a box, nailing it together with six-penny finishing nails.
10. For a drawer pull, make an opening in drawer front 1" wide by 4" long.
11. Put the top plank in place on cross sills and lay out and drill holes; one  $1\frac{1}{2}$ " from the back edge and one  $3\frac{1}{4}$ " from front edge.
12. Bore holes  $\frac{3}{4}$ " deep with  $\frac{7}{8}$ " bit.
13. Finish drilling holes thru plank and sills with  $\frac{3}{8}$ " bit.
14. Fasten plank to sills with  $\frac{3}{8}$ " x 7" carriage bolts, placing one washer on each bolt.
15. Plug the holes at top of plank.
16. Fasten the top board to sills with three  $1\frac{3}{4}$ " No. 8 or 9 flat-head screws.

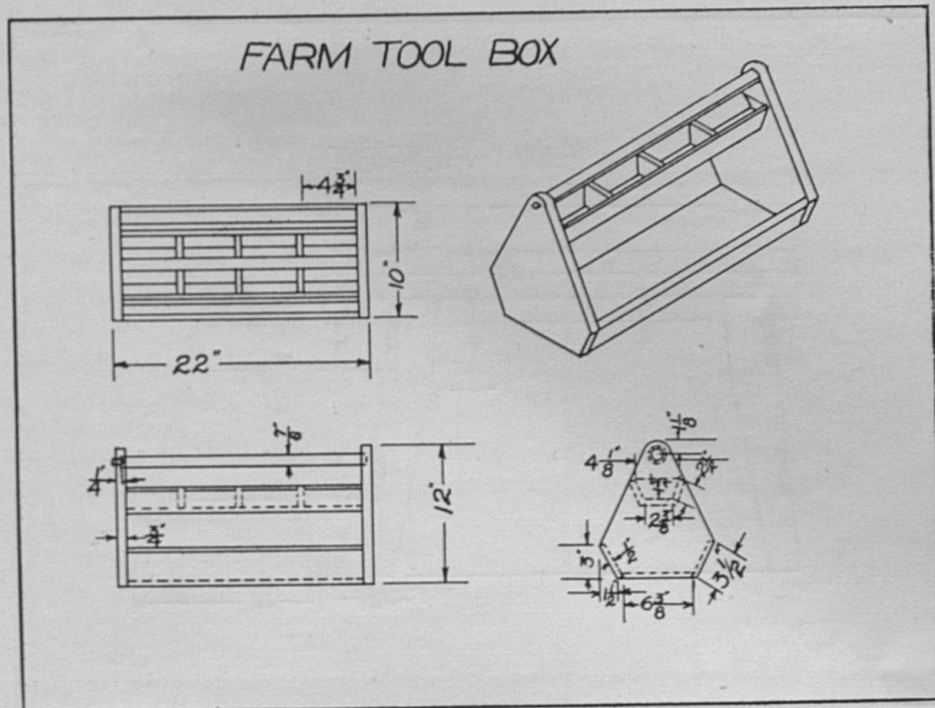

**FARM TOOL BOX**  
Bill of Materials

Use	No. of Pieces	Size
Ends	2	$\frac{3}{4}$ " x 10" x 12"
Bottom	1	$\frac{1}{2}$ " x $6\frac{3}{8}$ " x $20\frac{1}{2}$ "
Sides	2	$\frac{1}{2}$ " x $3\frac{5}{8}$ " x $20\frac{1}{2}$ "
Bottom of nail tray	1	$\frac{1}{2}$ " x $2\frac{3}{8}$ " x $20\frac{1}{2}$ "
Sides of nail tray	2	$\frac{1}{2}$ " x $2\frac{1}{2}$ " x $20\frac{1}{2}$ "
Partitions in nail tray	3	$\frac{1}{2}$ " x $1\frac{3}{4}$ " x $4\frac{1}{8}$ "
Handle	1	$\frac{7}{8}$ " round x 21" long

**Hardware:**

- 2 flat-head bright wood screws, 2 inches, No. 10 for handles.
- 3 doz. 6d finishing nails.
- 4 doz. 4d finishing nails.

**DIRECTIONS**

The tool box should be made of a light wood surfaced on both sides and edges. The purpose of it is to furnish a means of carrying a quantity of tools, nails, screws and staples needed for doing odd jobs around the farm.

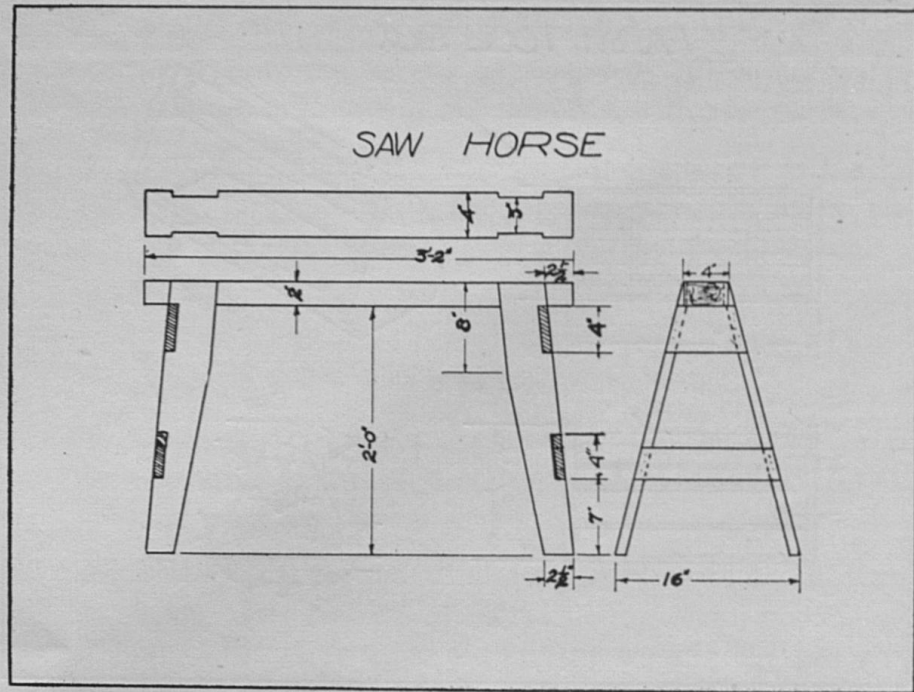

## SAWHORSE

## Bill of Materials

Use	No. of Pieces	Size
Top or saddle	1 pc. S 2 S	2" x 4" x 38"
Legs	4 "	2" x 4" x 26 1/2"
Braces	1 "	7/8" x 3 3/4" x 15"
Braces	1 "	7/8" x 3 3/4" x 26"

## DIRECTIONS

The sawhorse should be made out of material surfaced two sides. Before starting to lay out the material for the sawhorse, a careful study should be made of the drawings, as the legs fit to the saddle at two different angles. The cuts for these may be determined by laying them out with a square, using for one cut 2 1/2" on one leg of the square and 22" on the other. For the other cut use 6 1/2" and 22". The cuts for these angles may also be obtained by holding leg against the saddle at the correct slants and then marking it. After laying out one leg, it can be

used as a pattern, remembering that the angles are cut opposite on the other end of the horse. The saddle, legs and braces may be fastened together with nails or screws.

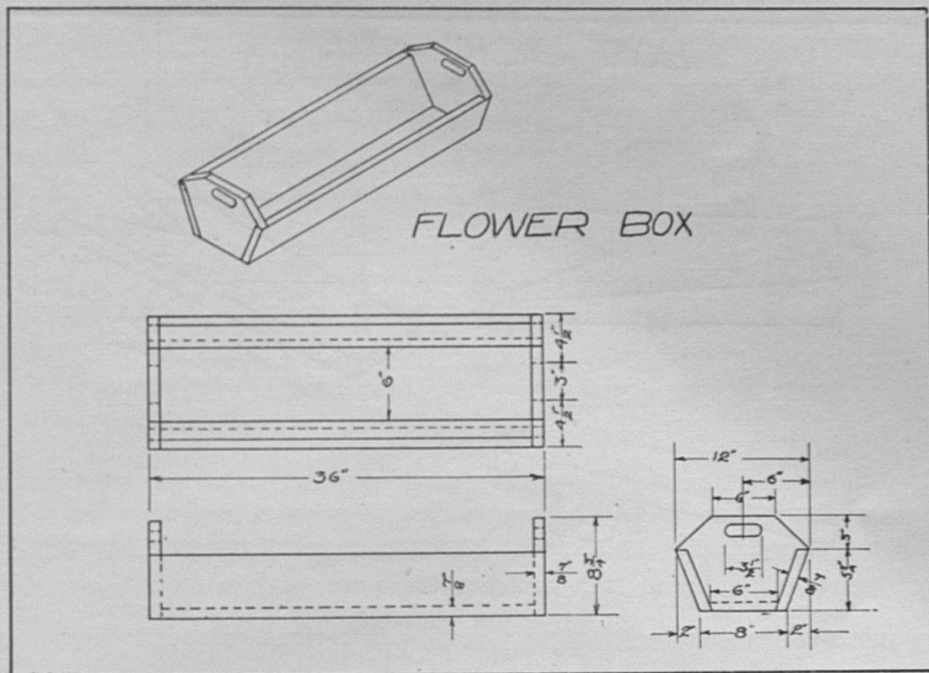

**FLOWER BOX—  
Bill of Materials**

Use	No. of Pieces	Size
Bottom	1	7/8" x 6" x 36"
Sides	2	7/8" x 6" x 36"
Ends	2	7/8" x 12" x 8 3/4"

**DIRECTIONS**

The flower box should be made of cypress or some soft wood surfaced two sides. Care should be taken to lay out all pieces according to dimensions given on the drawings. Before assembling the parts, the joints should be painted so as to prevent their rotting. The box should be painted inside and out with two coats of paint. Sometimes holes are drilled in the bottom of

the box so as to prevent the plants being drowned out by too much water.

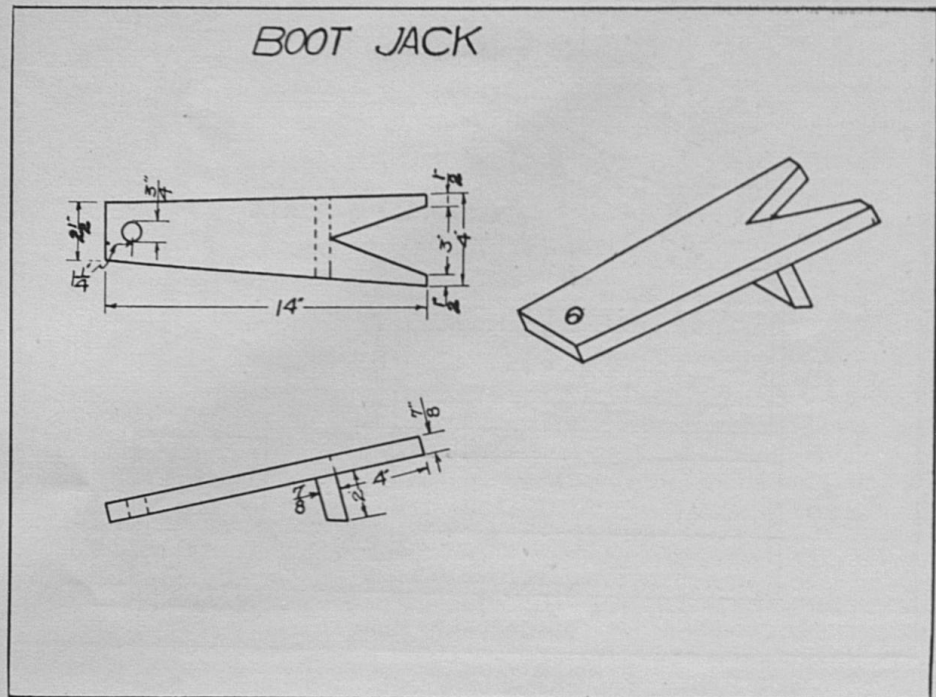

### BOOTJACK

#### Bill of Materials

Use	No. of Pieces	Size
Top	1 pine S 2 S	7/8" x 4" x 14"
Cleat	1 pine S 2 S	7/8" x 2" x 4"

### DIRECTIONS

The bootjack should be made of a clear piece of pine surfaced on both sides and should be finished with stain and wax or varnish.

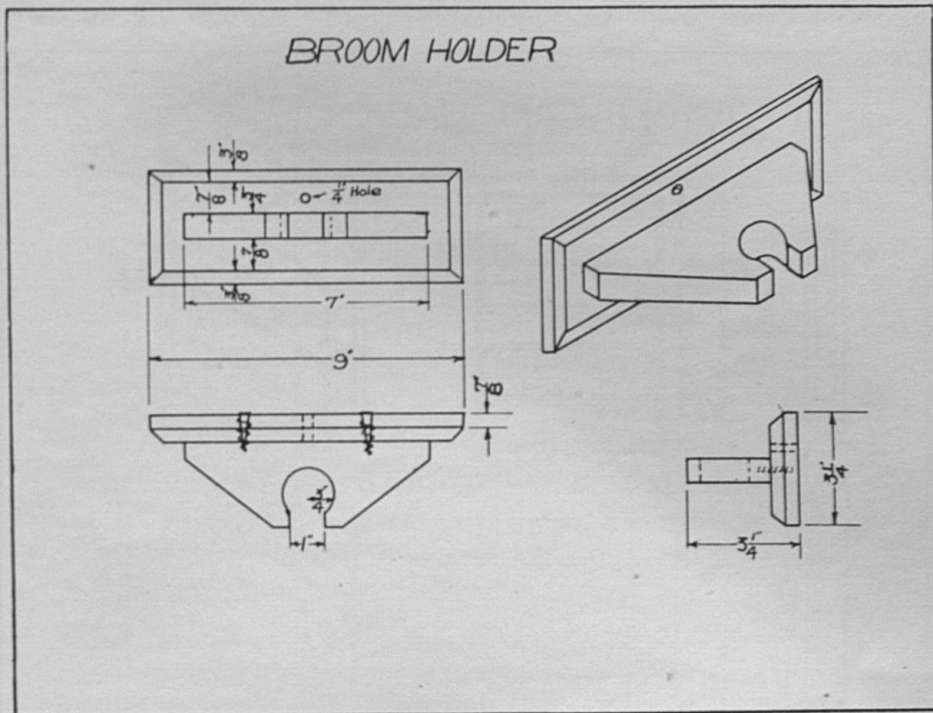

**BROOM HOLDER**  
Bill of Materials

Use	No. of Pieces	Size
Back	1 yellow pine S 2 S	$\frac{3}{4}$ " x $3\frac{1}{2}$ " x $9\frac{1}{2}$ "
Hanger	1 yellow pine S 2 S	$\frac{3}{4}$ " x 3" x 8"

2—No. 10 flat-head screws,  $1\frac{1}{2}$ ".

**DIRECTIONS**

The broom holder should be made of material surfaced 2 sides and smoothed with sandpaper.

The holder should be carefully laid out with a compass and square. The hole can be cut by using a coping or compass saw. Carefully smooth all the edges with a wood file and then sandpaper.

The two parts of the holder should be fastened together with glue and screws. Finish with stain and wax or varnish.

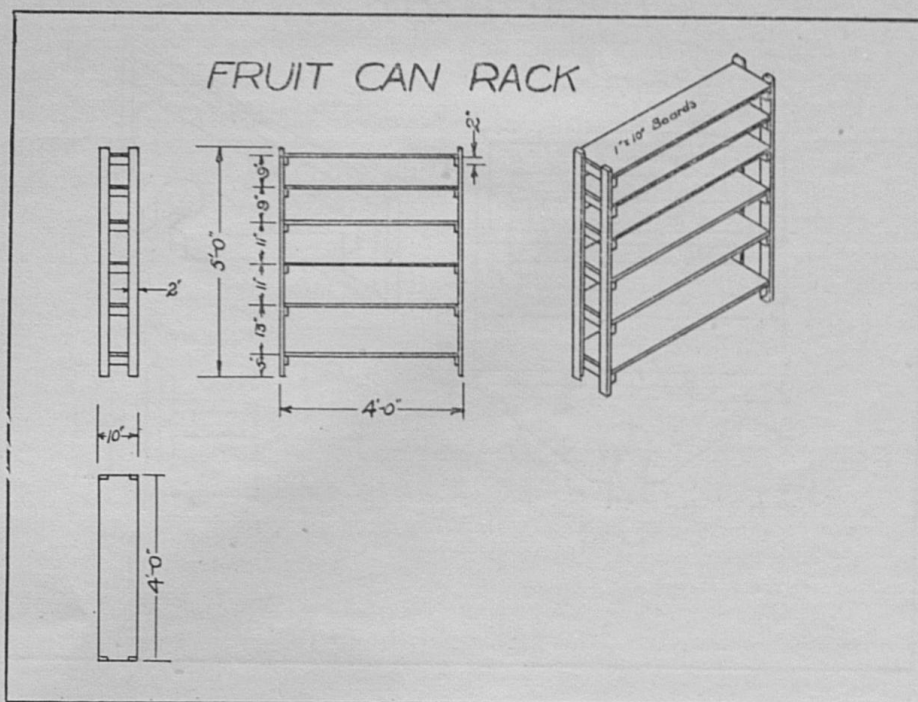
**FRUIT CAN RACK****Bill of Materials**

Use	No. of Pieces	Size
Posts	4	1" x 2½" x 5'
Cleats	12	1" x 2" x 10' 4"
Shelves	12	1" x 2" x 3' 10¼"

**Nails:**

$\frac{3}{4}$  lb. 6d nails.

**DIRECTIONS**

Soft lumber surfaced on one side and two edges should be used in constructing the fruit can rack.

Nail each end of cleats to post with 6d common nails.



Wood-Working Merit Course—Junior Agricultural Clubs 17

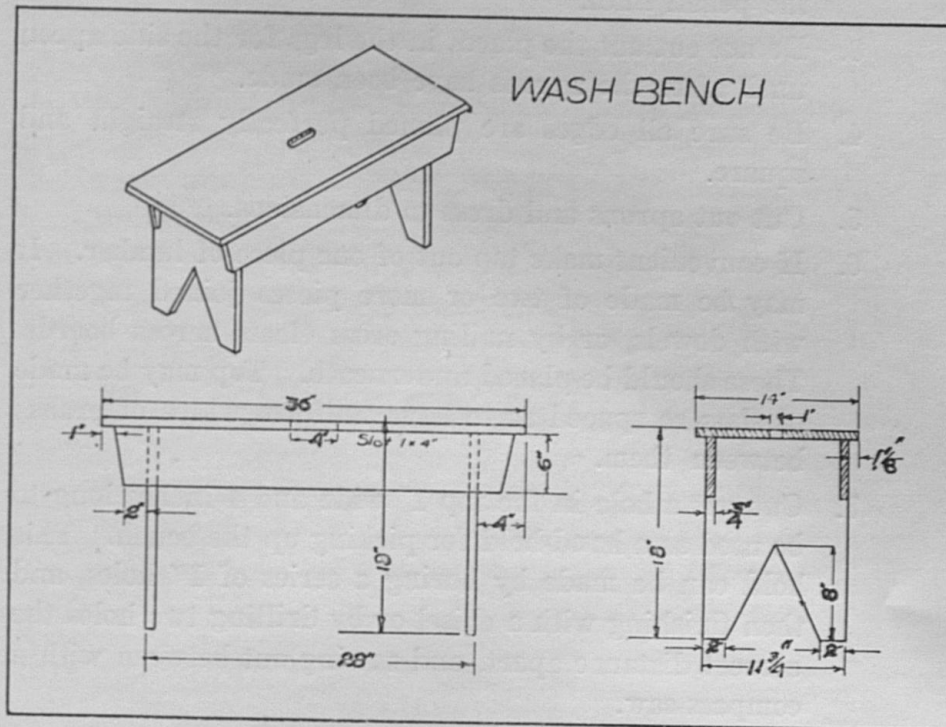

WASH BENCH

Bill of Materials

Use	No. of Pieces	Size
Legs	2	1" x 12" x 18"
Top	1	1" x 14" x 3' 0"
Sides or aprons	2	1" x 6" x 34"

$\frac{1}{4}$  lb. 6d common nails.

DIRECTIONS

Use lumber surfaced on two sides and edges.

1. Carefully lay out the shape of the legs to dimensions by using a carpenter's square and pencil.

2. Cut out legs with a crosscut saw, carefully cutting to the pencil lines.
3. Do not cut out the places in the legs for the side apron until after the aprons have been made.
4. Be sure all edges are planed perfectly straight and square.
5. Cut out aprons and dress to dimensions.
6. If convenient make top out of one piece of lumber. It may be made of two or more pieces joined together with dowels, or by nailing cross cleats across boards. These should be placed underneath. Top may be made of slats so spaced as to have uniform width of cracks between them.
7. Cut out a hole in the top 1" wide and 4 inches long to be used as a hand-hold for picking up the bench. This hold can be made by boring a series of 1" holes, and then finishing with a chisel or by drilling two holes the correct distance apart, and sawing out between with a compass-saw.
8. Nail aprons to the legs with 6d nails, testing with a square to see that the legs stand exactly at right angles to aprons.
9. Nail top to legs and apron boards.
10. Paint the bench with two coats of good paint to protect it from the water.

## MITER BOX

## Bill of Materials

Use	No. of Pieces	Size
Bottom	1	1½" x 3½" x 24"
Sides	2	¾" x 3¾" x 24"

10 bright, flat-headed screws 1¾", No. 9.

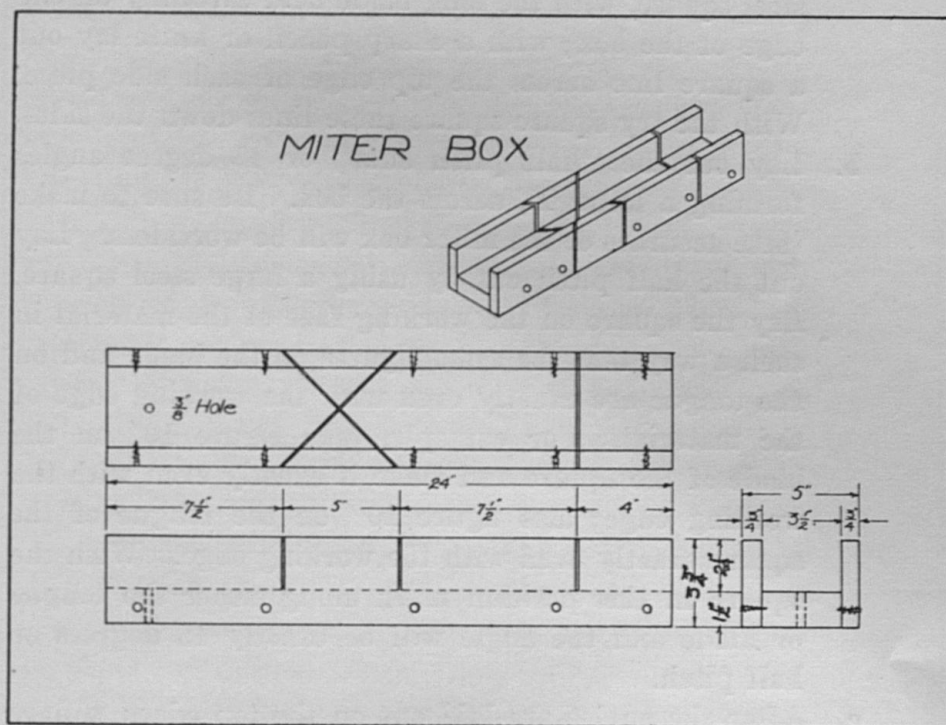

#### DIRECTIONS

1. The bottom should be made of a clear piece of perfectly sound lumber.
2. Select the best surface of the bottom piece and mark it the working surface.
3. Plane one edge perfectly straight and square for a working edge.
4. Gauge the width on both surfaces.
5. Plane to gauge lines.
6. Be sure that both edges are perfectly square with the working surface.
7. Prepare the sides according to dimensions.
8. The two sides are to be fastened to the edges of bottom piece with screws, making the bottom edge perfectly even. Place the screws so that they will not interfere with the sawing.
9. Lay out the angles.
  - a. The miter box should have one perfectly square cut near one end. Lay it out very accurately with a large

- steel square, with the long blade held carefully on one edge of the box; with a sharp pencil or knife lay out a square line across the top edge of each side piece. With the try square square these lines down the sides.
- b. Lay out the "half pitch cuts" or 45 degree angles forming a letter X, across the box. Be sure to make these accurate or the miter box will be worthless. Lay out the half pitch cut by using a large steel square. Lay the square on the working face of the material in such a way that the same figures on the blade and on the tongue are exactly even with the working edge of the material. For example, take figure 10" on the blade of the square and make it exactly even with the working edge; also figure 10" on the tongue of the square exactly even with the working edge. With the square in this position mark along either the tongue or blade and the angle will be exactly 45 degrees or half pitch.
  - c. After the angles are laid out on the top edges, square down the two sides with the try square.
  - d. Sawing these angles is the most particular part in constructing the miter box. Be sure to follow the guide lines.
10. Finish box with sandpaper and give it one or two coats of shellac to protect it from moisture and dirt.

**FLOWER TRELLIS**  
Bill of Materials

Use	No. of Pieces	Size
Upright	1	$\frac{7}{8}$ " x 2" x 5'
Crossbars	4	$\frac{7}{8}$ " x 1" x 30"
Crossbars	1	$\frac{7}{8}$ " x 1" x 26"
Crossbars	1	$\frac{7}{8}$ " x 1" x 24"
Crossbars	1	$\frac{7}{8}$ " x 1" x 12"
Brackets	2	$\frac{7}{8}$ " x 6" x 7"
Brackets	2	$\frac{7}{8}$ " x 4" x 4"
Soft iron wire	2	50'

16  $\frac{3}{4}$ " staples, 2- $\frac{1}{2}$  doz. 6d finishing nails.

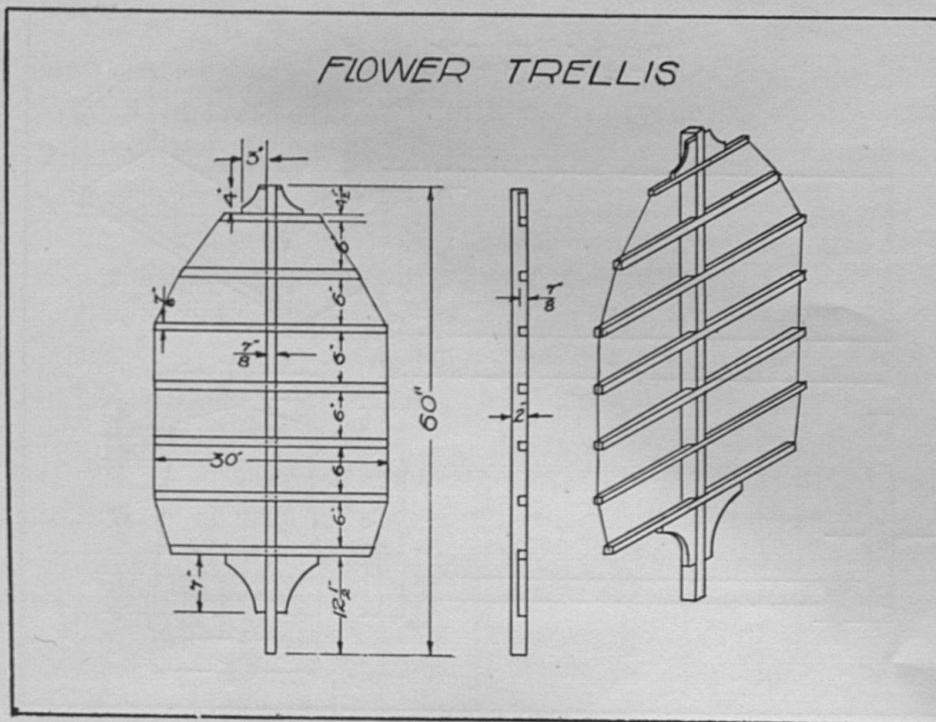

#### DIRECTIONS

1. Make the upright out of material surfaced on all four sides, making each side square with the adjacent ones.
2. With a try square, lay out and square across the upright piece, where it is to be cut out for the cross-bars. Be careful not to cut out too wide a space or the cross-bars will not fit.
3. With a marking gage, gage depth of cut. Saw out the wood just inside of the pencil marks with a back-saw or cross-cut saw.
4. Chisel out the material to the depth of gage marks with a sharp chisel.
5. Fasten the cross-bars in place with nails.
6. Saw out the brackets to any suitable design. Use a coping-saw or compass-saw. Fasten them in position with nails.
7. Fasten the wire to the outer ends of cross-bars with staples.
8. Paint the trellis to protect it from the weather.

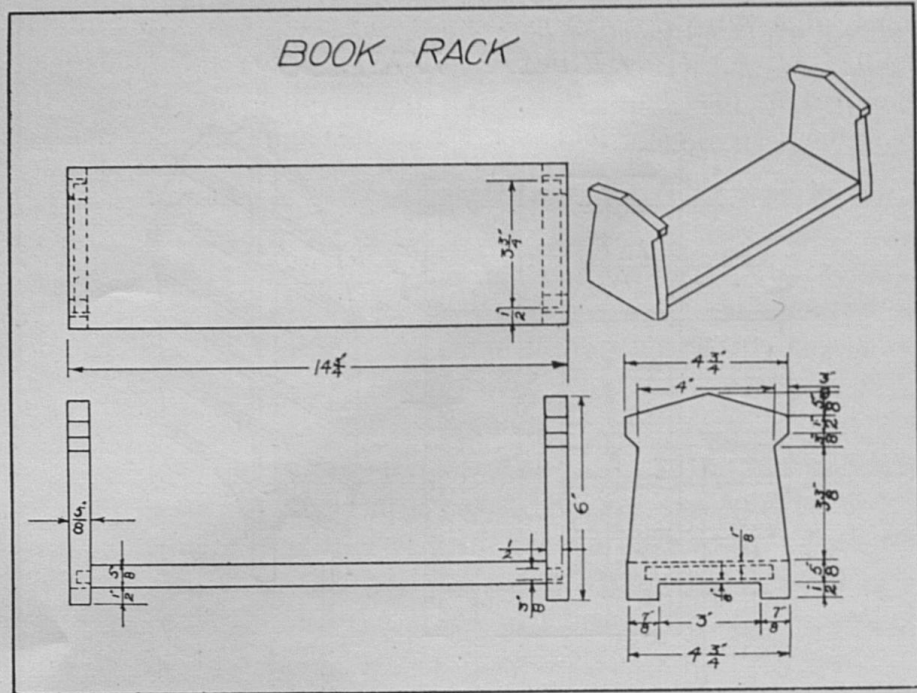

**BOOK RACK**  
Bill of Materials

Use	No. of Pieces	Size
Bottom	1	$\frac{5}{8}$ " x $4\frac{3}{4}$ " x $14\frac{3}{4}$ "
Ends	2	$\frac{5}{8}$ " x $4\frac{3}{4}$ " x 6"

#### DIRECTIONS

The book rack should be made of oak, walnut or some other hard wood. Great care should be taken in laying out and cutting the ends and mortises for the bottom. Before assembling, scrape and sandpaper all broad surfaces. Fasten the parts with fish or animal glue and small brads.

The glue should be heated by placing the glue pot in an outer vessel of water which can be heated in any convenient way. When ready for use, the glue should be hot and of the consistency of thin sirup. It must be applied with a brush in a thin, uniform coat, to both surfaces that are to be joined, and must be well brushed into the pores of the wood. Too

much glue will prevent the pieces from coming together in the joint. After the pieces have been put together they should be clamped in place and left until dry. Finish by staining the rack the desired color and then fill, shellac and wax, or varnish.

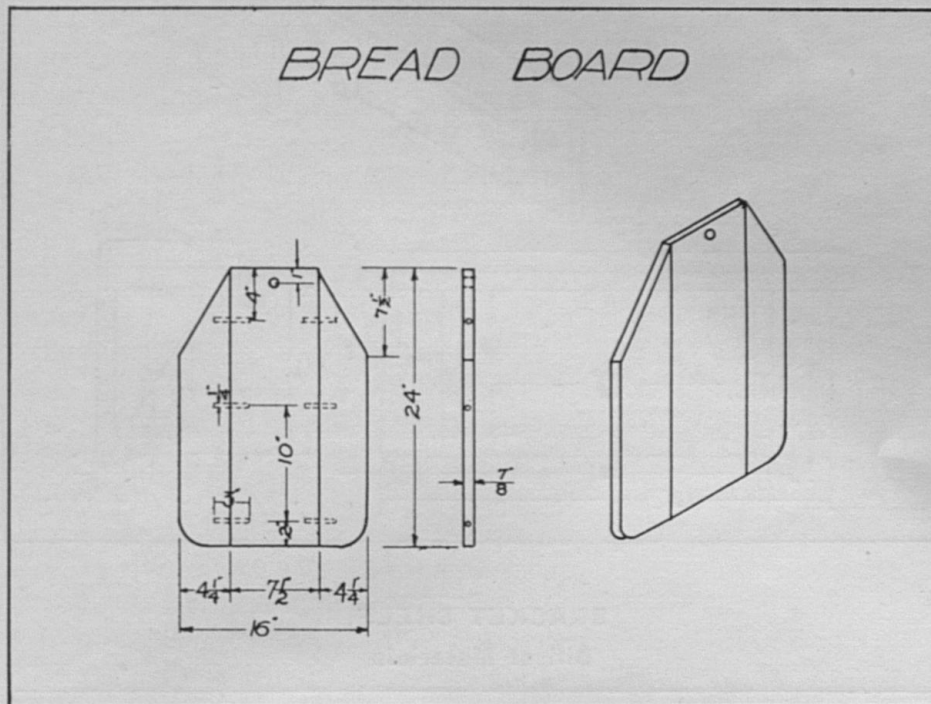

**BREAD OR MEAT BOARD**

**Bill of Materials**

Use	No. of Pieces	Size
Center piece	1	1 1/4" x 8" x 24 1/2" S 2 S
Sides	2	1" x 5" x 24 1/2" S 2 S
Dowel pins	1	1/4" x 10"

**DIRECTIONS**

The bread or meat board should be made of soft wood such as yellow poplar. The wood should be close grained so as to be as non-absorbent as possible. It should be free from cracks or any places which would make it hard to keep clean. A board made of three pieces fastened together with glue and dowel pins is not apt to warp.

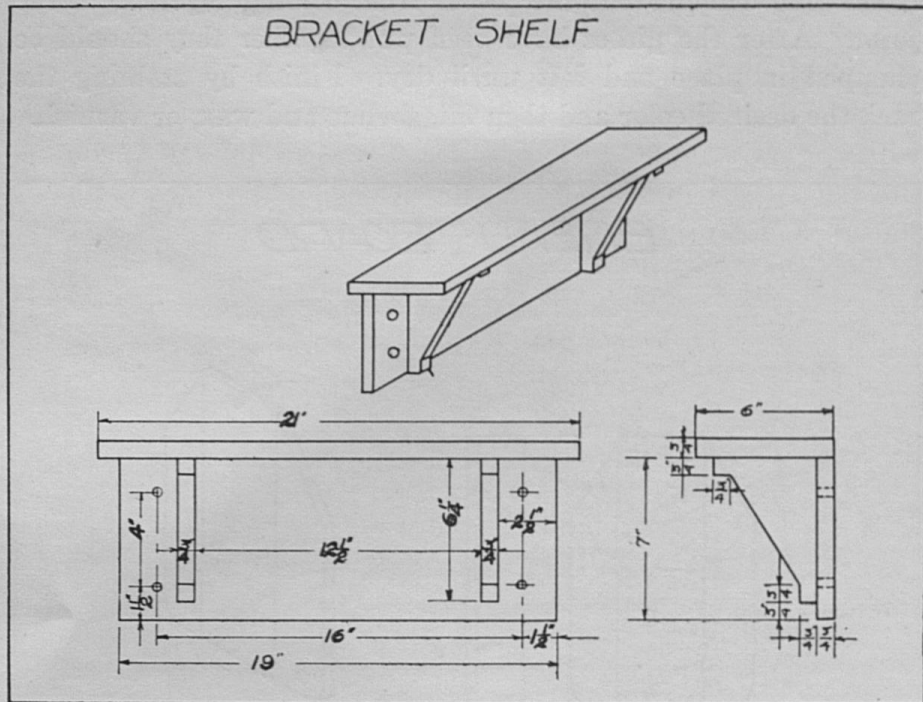

## BRACKET SHELF

## Bill of Materials

Use	No. of Pieces	Size
Top	1 S 2 S	$\frac{7}{8}$ " x $6\frac{1}{4}$ " x $21\frac{1}{2}$ "
Back	1 S 2 S	$\frac{7}{8}$ " x $7\frac{1}{4}$ " x $19\frac{1}{2}$ "
Brackets	1 S 2 S	$\frac{7}{8}$ " x 5" x 10"

12 6d finishing nails

## DIRECTIONS

The shelf can be made of yellow pine or oak dressed two sides and smoothed with sandpaper.

In making the bracket care should be taken in cutting it out to get it true to design. It should be carefully sawed out with a turning or coping or compass saw and then the edges



should be made perfectly smooth with a wood file and sandpaper.

Make the second bracket exactly like the first.

The shelf may be assembled by fastening the pieces together with screws or brads. The nails or brads should be counter-sunk and the holes puttied. The shelf should be sandpapered smooth and finished by staining, then shellacking and waxing, or varnishing.

**FLY TRAP**  
Bill of Materials

Use	No. of Pieces	Size
Sides	8 pcs. S 2 S	$\frac{3}{8}$ " x 1" x $12\frac{1}{2}$ "
Cross	8 pcs. S 2 S	$\frac{3}{8}$ " x 1" x $7\frac{1}{2}$ "
Trim	8 pcs. S 2 S	$\frac{1}{4}$ " x $\frac{3}{4}$ " x 9"
Top	5 pcs. S 2 S	$\frac{1}{2}$ " x $\frac{3}{4}$ " x 9"

**Hardware:**

- 3 doz  $\frac{1}{2}$ " brads
- 1 doz 1" brads
- $1\frac{1}{2}$  doz.  $\frac{3}{8}$ " corrugated nails.
- 1 yd. 24" screen wire
- 9 doz small tacks
- 1 pc.  $\frac{5}{32}$ " Bessemer rod 8" long
- 2 screw eyes, No. 114
- 1 pair  $\frac{3}{4}$ " x  $\frac{3}{4}$ " brass hinges
- 1 small clasp

**DIRECTIONS**

The frame for the fly trap will have to be ripped from stock and planed down to size. The different pieces may be accurately sawed to length in a miter box. All joints are plain butt joints. The ends and top of the trap consist of five rectangular frames covered with fly screening fastened together box fashion.

The pattern for the inside wire pyramid can be made out of paper. Make four triangles the size of each side of the pyramid as shown in the drawings. Fasten them together so that they join each other and you will have a correct pattern by which to cut out wire for pyramid. Allow about one inch of



# STEPLADDER

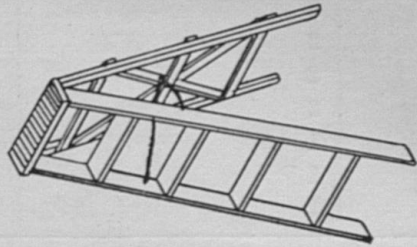
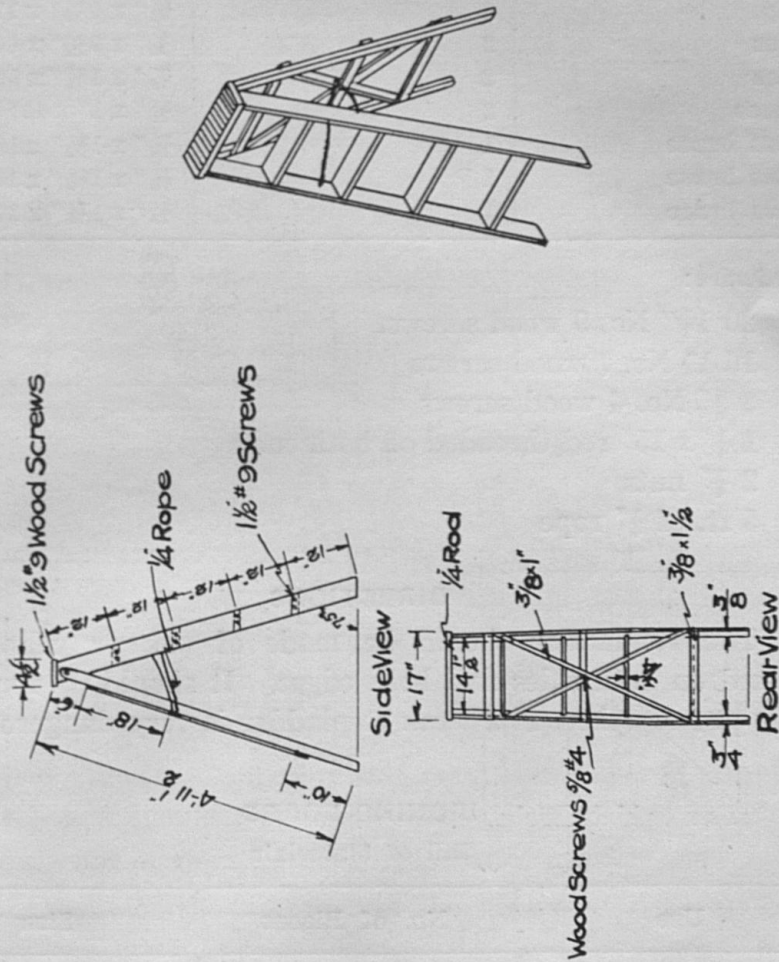

**STEPLADDER**  
Bill of Materials

Use	No. of Pieces	Size
Step	1	$\frac{3}{4}$ " x 4" x 16 $\frac{1}{2}$ "
Step	1	$\frac{3}{4}$ " x 4" x 16"
Step	1	$\frac{3}{4}$ " x 4" x 15 $\frac{1}{2}$ "
Step	1	$\frac{3}{4}$ " x 4" x 15"
Step	1	$\frac{3}{4}$ " x 4 $\frac{1}{2}$ " x 17"
Sides	2	$\frac{3}{4}$ " x 3 $\frac{1}{2}$ " x 60"
Sides	2	$\frac{3}{8}$ " x 1 $\frac{3}{4}$ " x 59 $\frac{5}{8}$ "
Braces	2	$\frac{3}{8}$ " x 1" x 42"
Cross brace	1	$\frac{3}{8}$ " x 1 $\frac{1}{2}$ " x 18"
Cross brace	1	$\frac{3}{8}$ " x 1 $\frac{1}{2}$ " x 16"
Cross brace	1	$\frac{3}{8}$ " x 1 $\frac{1}{4}$ " x 17"

**Hardware:**

- 20 1 $\frac{1}{2}$ " No. 9 wood screws.
- 16 1" No. 7 wood screws
- 3  $\frac{5}{8}$ " No. 4 wood screws
- 1  $\frac{1}{4}$ " x 15" rod threaded on both ends
- 2  $\frac{1}{4}$ " nuts
- 5 ft. of  $\frac{1}{4}$ " rope

**DIRECTIONS**

The stepladder should be made of oak or yellow pine dressed on both sides and both edges. It should be very carefully put together, as a weak stepladder is very dangerous.

**IRONING BOARD**  
Bill of Materials

Use	No. of Pieces	Size
Ironing board	1	1 $\frac{1}{4}$ " x 15" x 4' 8"
Brace	1	1" x 4" x 54"
Board strip	1	1" x 4" x 8"
Wall strip	1	1 $\frac{1}{4}$ " x 4" x 15"
Board holder	1	2 $\frac{1}{2}$ " x 5" x 12"

Wood-Working Merit Course—Junior Agricultural Clubs 29

- 3 3-inch butt hinges and screws
- 1 pc. of galvanized iron 6" x 15"
- 1 pc. of strap iron  $\frac{3}{16}$ " x 1" x 4"
- 2 No. 3 $\frac{1}{2}$ " wood screws

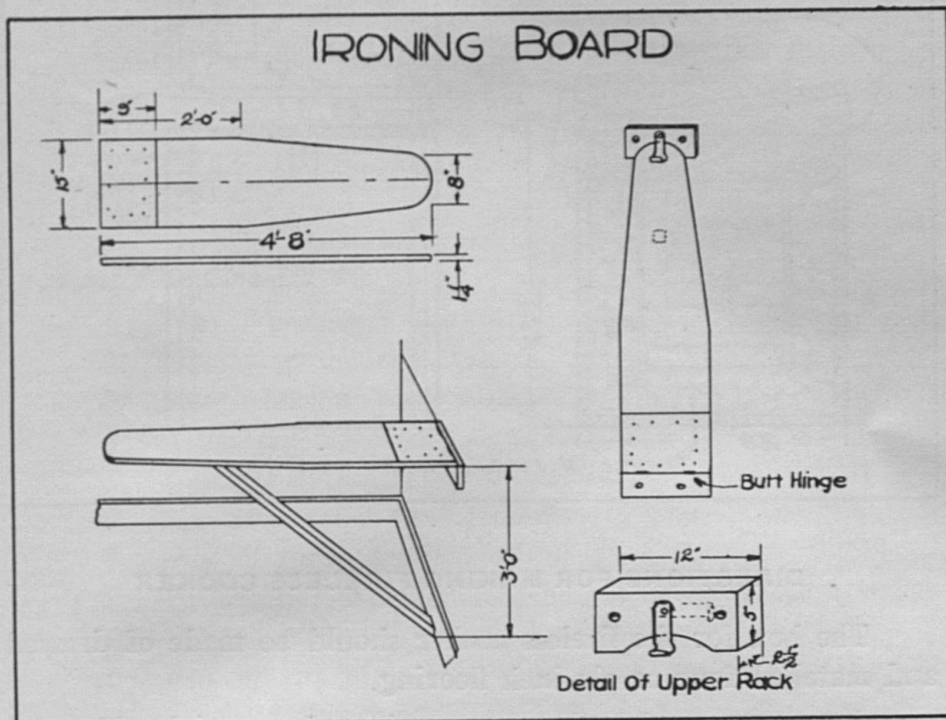

**DIRECTIONS**

The ironing board should be made of well seasoned 1" or 1 1/4" material surfaced on four sides and sandpapered smooth.

The board should be hinged to the wall so that it can be fastened up out of the way when it is not in use.

The height of the board from the floor should be made to suit the height of the user. On an average it should be about 32 inches from the floor.

A piece of galvanized iron or of asbestos board may be tacked to the board on which to put the hot iron when not being used.

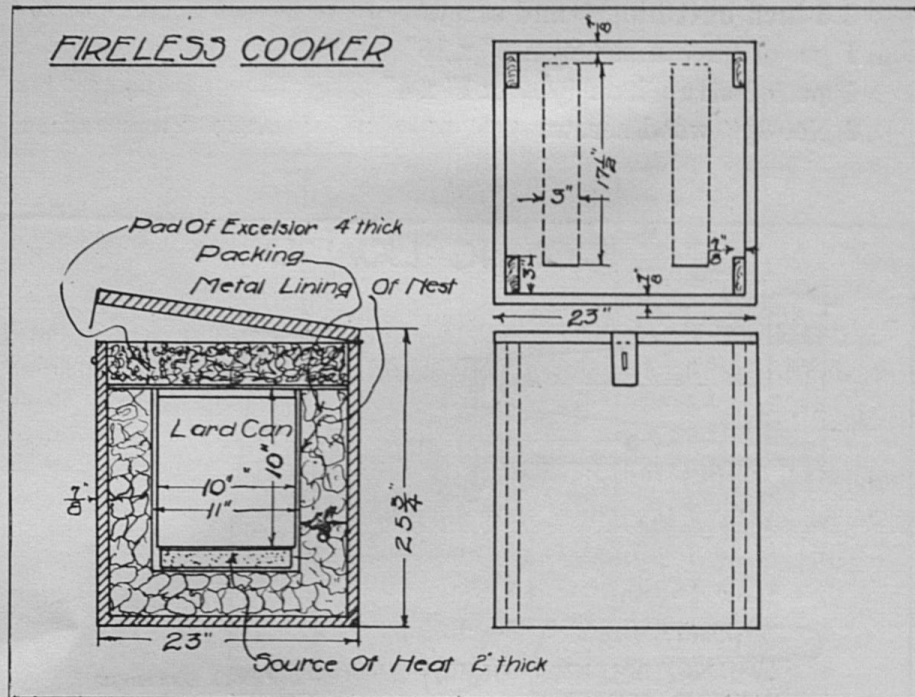

#### DIRECTIONS FOR MAKING FIRELESS COOKER

The box for the fireless cooker should be made of dressed and matched four or six inch flooring.

A twenty-pound lard can or a pail having straight sides and a tight cover may be used for the metal lining of the nest.

Under the bottom and around the metal pail should be placed several layers of sheet asbestos or heavy cardboard, to prevent the hot stone from scorching the packing.

The packing or insulating material must be some material which is a poor conductor of heat. It may be shredded newspaper, straw, excelsior, fine asbestos or slag wool.

Around the top of the metal lining should be placed a collar made of metal, of cardboard or of wood to cover the exposed surface of the insulating material.

For the top pad make a cushion filled with insulating material. The pad should be at least four inches thick and should so completely fill the space between the top of the container lid

and the top of the box, that it will require pressure to close the top.

The outside of the box may be made more attractive by painting or staining and varnishing it. It may be placed on casters so that it can be easily moved.

### STORY

The story must be written by the club member. Pen and ink should be used; everything of interest should be included in the story.

#### **Suggested Outline for the Story:**

1. Why I became a club member.
2. How I joined the club.
3. How I obtained my tools.
4. A description of my shop.
5. Where I obtained the materials.
6. List of articles that I made.
7. Cost of three articles.
8. Interesting experiences I had in making the articles.
9. What has the club work done for me.
10. Put in anything else of interest, such as pictures of some of the finished articles, and a picture of your shop.

## COST SHEET

Name of article .....

Amount of Material	Kind	Cost

Total cost of material .....

Time required to make article (hours).....

Remarks .....

.....

## REFERENCES

In planning and preparing this circular, plans and suggestions were obtained from the following publications:

"Shop Projects" (Based on Community Problems), Vocational Supply Company, by Burton, Muncie, Indiana.

"Farm Wood Work," by L. M. Roehl, Bruce Publishing Company, Milwaukee.

"Wood Working Exercises," by H. B. White, for Agricultural School Shop. Bul. 135, University of Minnesota.

"Farm Home Conveniences," Farmers' Bulletin 927, U. S. Dept. of Agriculture.